

**Ministry of Transport,  
Socialist Republic of Viet Nam**

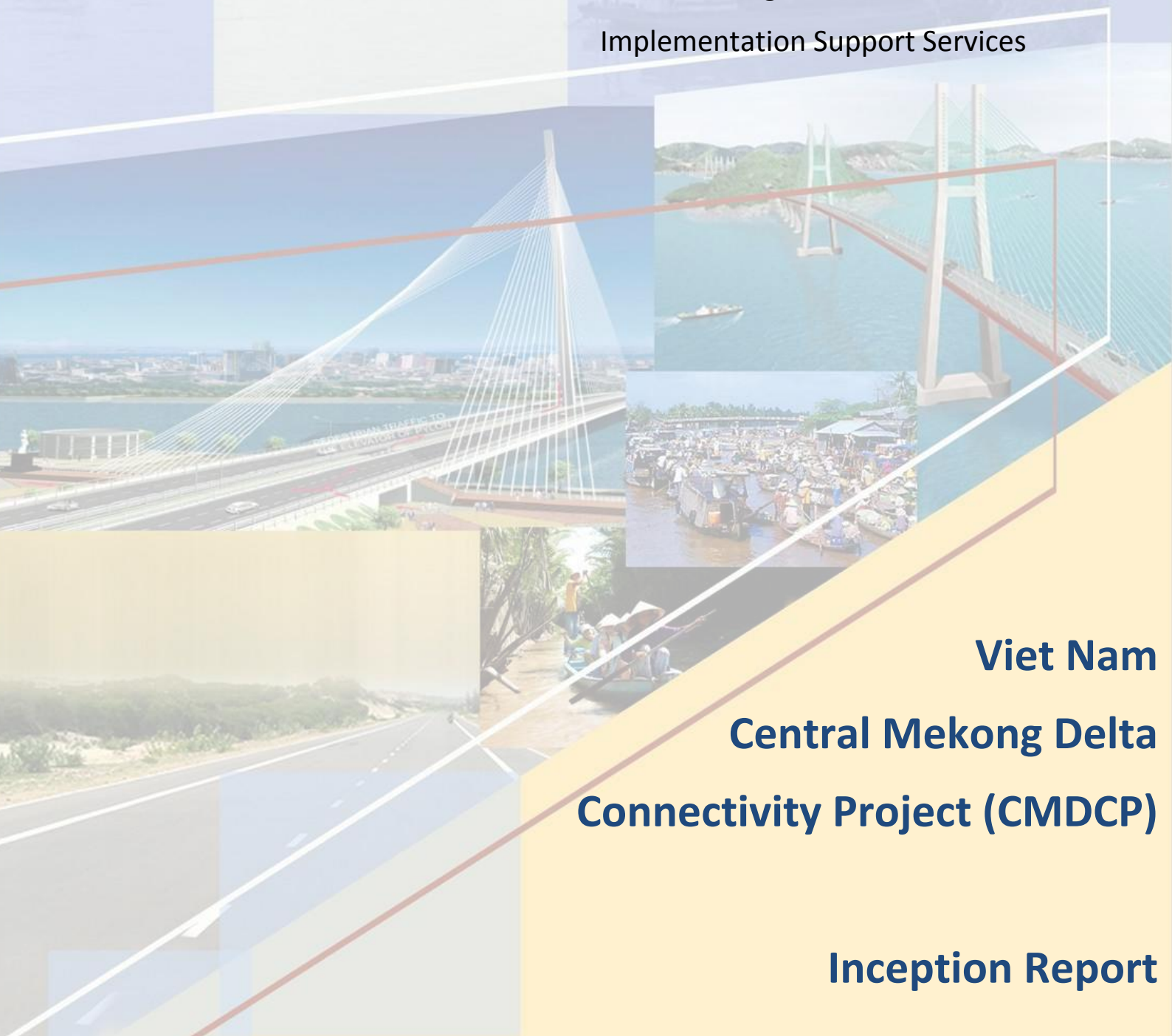

**CUU LONG CORPORATION FOR INVESTMENT,  
DEVELOPMENT AND PROJECT MANAGEMENT  
FOR INFRASTRUCTURE (CUU LONG CIPM)**

Detailed Design, Procurement and  
Implementation Support Services



**Viet Nam  
Central Mekong Delta  
Connectivity Project (CMDCP)**

**Inception Report**

**20 December 2011**

**CUU LONG CORPORATION FOR INVESTMENT,  
DEVELOPMENT AND PROJECT MANAGEMENT  
FOR INFRASTRUCTURE (CUU LONG CIPM)**

**Ministry of Transport,  
Socialist Republic of Viet Nam**

Detailed Design, Procurement and  
Implementation Support Services

	Name	Position	Signature	Date
Prepar	Brian	Project		
Check	Karl Close	Project Quality		
Appro	Brian	Project		

Joint Venture:



**Wilbur Smith Associates, Inc.**

Suite 909, Wave Plave,  
55 Wireless Rd., Bangkok, Thailand

**WSP Finland Limited**

Heikkilantie 7,  
00210, Helsinki, Finland



**Yooshin Engineering  
Corporation**

832-40 Yoksam-dong, Gangnam-gu,  
Seoul, Korea

**Viet Nam**

**Central Mekong Delta**

**Connectivity Project  
(CMDCP)**

**Inception Report**

**20 December 2011**

# Viet Nam – Central Mekong Delta Connectivity Project (CMDCP)

## Inception Report

### Contents

<b>1. Introduction.....</b>	<b>5</b>
1.1 Project Background.....	5
1.2 Objectives of the Consultant’s Services.....	8
1.3 Scope of Services .....	8
<b>2. Technical Approach &amp; Methodology for Detailed Design .....</b>	<b>11</b>
2.1 General Approach of the Consultant .....	11
2.2 Data Collection and Surveys .....	11
2.3 Highways and Interchanges .....	24
2.4 Bridges on the Project.....	28
2.5 Small/Medium Bridges and Cable Stay Bridge Approaches .....	29
2.6 Cao Lanh Cable Stayed Bridge.....	48
2.7 Geotechnical Design and Soft Ground Treatment.....	74
2.8 Toll Collection and Central Control Facilities .....	78
<b>3. Safeguards &amp; Other Project Requirements .....</b>	<b>81</b>
3.1 Environmental Management and Monitoring.....	81
3.2 Resettlement.....	85
3.3 Indigenous People (Ethnic Minorities).....	88
3.4 Social Development and Gender Issues.....	89
3.5 Communicable Disease, Trafficking Awareness and Prevention.....	90
3.6 Training and Capacity Building in Social Safeguards.....	91
3.7 Project Performance Monitoring.....	92
3.8 Anti-Corruption Action Plan.....	93
3.9 Training (Technology Transfer) .....	93
3.10 Reporting .....	95
3.11 Climate Change .....	95
3.12 Project Components .....	101
3.13 General Approach to Procurement.....	101

---

3.14	Construction Planning and Packaging of works.....	101
3.15	Preparation of Bidding Documents.....	102
3.16	Pre-construction Activities - Prequalification and tendering.....	102
<b>4.</b>	<b>Staff Organization, Work Plan and Personnel .....</b>	<b>104</b>
4.1	General.....	104
4.2	Project Organization .....	104
4.3	Work Schedule .....	104
4.4	Staffing Schedule .....	104
<b>5.</b>	<b>Identified Constraints .....</b>	<b>106</b>

**Annex A – Staff Organization Chart**

**Annex B – Project Schedule**

**Annex C – Staff Schedule**



## SECTION 1

# INTRODUCTION

# Viet Nam – Central Mekong Delta

## Connectivity Project (CMDCP)

### Inception Report

## 1. Introduction

### 1.1 Project Background

Ho Chi Minh City (HCMC) is the economic hub of Vietnam and is the largest city in the country. The population of HCMC is forecasted to grow by 2.1% per annum with a resulting population increase from the present 7.9 million to 10.3 million in the year 2020.

The Cuu Long delta of the downstream Mekong River is just to the Southwest of HCMC and consists of 13 provinces, namely Can Tho, Long An, TienGiang, Ben Tre, TraVinh, Vinh Long, Dong Thap, HauGiang, SocTrang, Bac Lieu, Ca Mau, An Giang and KienGiang – see location plan below.

The area of the Cuu Long delta is 12% of the total area of Vietnam, or approximately 40,000 km<sup>2</sup>. The area is divided by many rivers, canals and floods annually. The area does not have a developed road transport system with many roads not technically classified, in poor condition, and hence making travel difficult during the rainy season.

The Cuu Long delta area has experienced a high growth rate in recent years averaging more than 12% per annum and even in 2009 during the world economic crisis experienced a growth rate of more than 9% per annum, higher than the average growth rate for the whole country. The delta area produces more than 50% of the food, 65% of aquatic and 70% of the fruit products of Vietnam. Many new industrial and urban areas have been created but the existing transportation infrastructure does not meet the requirements of the economic and social development, the comprehensive development strategy and hunger and poverty reduction in the area. The objective of this project, the Central Mekong Delta Connectivity Project, is to encourage the economic and social development of the Cuu Long delta area.





The project has been developed with the support of the Asian Development Bank and the Government of Australia who financed the Project Preparation Technical Assistance (PPTA) grant. Purpose of the grant was to develop the project to a level suitable for Asia Development Bank financing. The PPTA provided the resources necessary to prepare the project and identify adequate mitigation of the project’s social, resettlement, environmental and other impacts. The PPTA also reviewed and updated feasibility studies that the Government of Vietnam’s Ministry of Transport and its Project Management Unit had prepared for the project. The PPTA found the project to be economically feasible with social and environmental impacts that could be effectively mitigated. The PPTA study determined the estimated cost of the project to be in the order of US\$750 million. The government requested financing assistance for the project from the Asian Development Bank, the Government of Australia and the Government of Korea. The project, when completed, will be operated as a toll road with tolls set to at least recover operating and maintenance costs. Financing for the project has been arranged through the Asian Development Bank and the Government of Australia. The VAM CONG bridge will be separately financed by the Government of Korea.

There are three components to the Central Mekong Delta Connectivity Project:

- (i) The Cao Lanh bridge including the approach bridges and the approach road for a total length of 7.8km. The Cao Lanh Bridge itself will be a cable stayed bridge with a central span of 350m and a maximum clearance above high water of 37.5m. Including the approach spans the overall length of the Cao Lanh Bridge is approximately 2km and will be 6 lanes wide crossing a branch of the Tien River.
- (ii) A connecting road between the Cao Lanh and Vam Cong bridges will be approximately 15.7km long and will be designed to 6 lane expressway standards but will be constructed initially to 4 lanes.
- (iii) The Vam Cong cable stayed bridge with a central span of 470m. With the approach structures the total length will be 2.9km. This is designated component 3A. Component 3B is the approach road to the West of the bridge and is approximately 2.9km long.

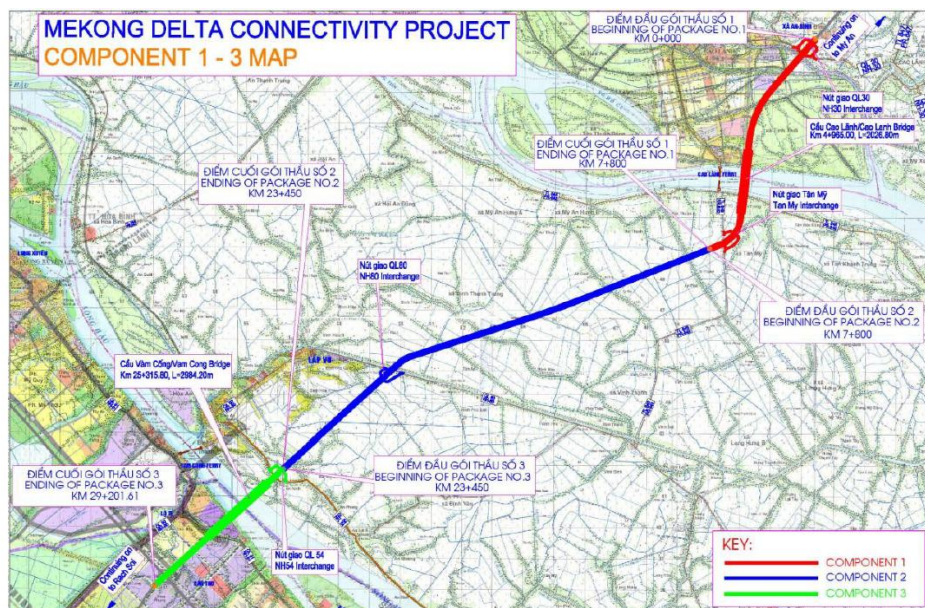

Figure 1: Connectivity Project Dong Thap Province and Can Tho City (Province)

The project for which the WSA-WSP-Yooshin JV is providing technical assistance is composed of the Cao Lanh Bridge, the connecting road between the two cable stayed bridges and the approach road to the West of the Vam Cong Bridge.

The project generally will be supported on soft ground which will require special methods to reduce settlements to acceptable limits. The interface area between bridges and culverts, which will be supported on concrete piles and thus subject to minimal settlement, and the adjacent highway embankments which will be subject to settlement over time will require special examination to determine an economic method of reducing the ‘step’ between the embankments and bridges to acceptable limits.



1 - Start of the project looking North along NH-30 – the site of a half-diamond interchange



2 - In the vicinity of the toll plaza looking East there is high groundwater and many inlets.



3 - Coa Lanh ferry location looking West



4 - Site of new Cao Lanh Bridge



5 - Site of 450m long flyover and half-diamond



6 - High groundwater levels are prevalent



*interchange at PR 849*



*7 - The West end of the project becomes more rural but high groundwater prevails throughout.*

*throughout the route.*



*8 - Immediately to the East of the Vam Cong Bridge site on NH54.*

## 1.2 Objectives of the Consultant's Services

In summary, the principal objectives of the Consultant's service are:

- To prepare a complete engineering detailed design of the expressway together with ancillary documents necessary for the construction of the Central Mekong Delta Connectivity Project, all the necessary plans and to prepare quantities and cost estimates for the same.
- To prepare procurement documents for the civil works and assist MOT/CUU LONG CIPM with the procurement.
- To provide implementation support, including supervision of the civil works contracts and other related activities.
- To update the Environmental Impact Assessment (EIA), the Environmental Management Plan (EMP), Resettlement Plan, Ethnic Minority Development Plan (EMDP) or Ethnic Minority Specific Action (EMSA) and other social development plans for this expressway and assist MOT/CUU LONG CIPM in implementing those plans.

## 1.3 Scope of Services

The Project Design Services are clearly set out in the Terms of Reference. For the Detailed Design and Procurement Stage the scope can be summarised as:

- (i) Reviewing all aspects of the PPTA feasibility study designs to determine the optimal solutions for detailed design. This task is to include reviewing CUU LONG CIPM 's feasibility study, on the basis of which the Government approved the project. Specifically, the review is to take into account aspects of the feasibility study design and other work that were identified as requiring further attention during the detailed design;
- (ii) Completing technical design of the project's road and structural works, based generally on the PPTA study and the Government's feasibility study approval, including all necessary site surveys and investigations – traffic, topographic, hydraulic and hydrologic, geotechnical, materials, morphological, & river studies;
- (iii) Arranging physical modeling of the Cao Lanh bridge structure to assess the its responses to wind, earthquake, traffic and other loadings that may occur during the bridge's construction, and during its service life;

- (iv) Arranging, if required, physical modeling of the river in the vicinity of the Cable Stay Bridge to assess the impact of the bridge on the river’s morphology, bank stability, etc.;
- (v) Identifying sources of construction materials;
- (vi) Preparing cost estimates;
- (vii) Preparing detailed procurement and construction schedules;
- (viii) Preparing bidding documents;
- (ix) Assisting CUU LONG CIPM with procuring contractors to construct the works;
- (x) Assisting CUU LONG CIPM and the provincial agencies in the updating, implementation, and monitoring of the resettlement plans based on detailed design;
- (xi) Ensuring that the project design complies with the environmental management plan (EMP) and that procurement documents include relevant EMP provisions;
- (xii) Assisting CUU LONG CIPM in the detailed planning and implementation of the Social Action Plan in close collaboration with relevant agencies and organizations;
- (xiii) Undertaking a baseline study for the project’s benefit monitoring program;
- (xiv) Undertaking an institutional assessment of CUU LONG CIPM , and identify areas that require capacity development, and prepare a capacity development plan;
- (xv) Preparing a management and operations strategy for the project when complete, including an appropriate asset management program for the project during its service life; and
- (xvi) Providing general project implementation support to CUU LONG CIPM during the detailed design phase, including for the quarterly Project Coordinating Committee meetings for which CUU LONG CIPM will be the secretariat.

## SECTION 2

# TECHNICAL APPROACH & METHODOLOGY FOR DETAILED DESIGN

## 2. Technical Approach & Methodology for Detailed Design

### 2.1 General Approach of the Consultant

The Wilbur Smith – WSP - Yooshin Joint Venture, through our previous involvement in design and implementation in Vietnam since 1995, and through our current involvement in the presently on going ADB funded Ho Chi Minh City – Long Thanh – Dau Giay Expressway (HLD) Project, has access to the developmental stages of Vietnam’s national highway program, the evolution of the national highway design standards, and the current state-of-the-art design and construction techniques and procedures.

To successfully assist MOT/CUU LONG CIPM, the Consultant can utilize valuable technical expertise gained from performing similar services on various projects throughout the Region and indeed the world. In the past, the Consultant has successfully applied the lessons attained from past experience for improving the quality of new Projects. The sections below discuss the various technical approaches to be adopted under the project and give the methodology to be followed in the detailed design process. A thorough review has been carried out of the Feasibility Study prepared previously and, where appropriate, any comments or issues relating to the review are discussed in the relevant sections below.

### 2.2 Data Collection and Surveys

In order to ensure that the design is based on reliable data a number of site survey and investigations are to be carried out covering topographical, geotechnical and hydrological/geomorphology aspects. These are given in more detail below.

#### 2.2.1 Topographical Site Survey

A topographical survey is currently being conducted along the project corridor and it is expected to be completed in early January 2012.

The Topographic Survey we will provide the following information:-

- Horizontal and vertical control data.
- Digital Terrain Model (DTM) of the whole of the project corridor including interchanges, intersections, other road crossings, bridge sites etc., and giving all details, spot levels, and contours (where feasible).”
- Primary horizontal control survey (X/Y coordinates) tied to the Vietnam national coordinate system, including establishment of pillars.
- Primary vertical control survey (elevation) tied to the Vietnam national elevation. Same stations as the primary horizontal control survey points to be adopted.
- Secondary horizontal control survey (X/Y coordinates) tied to the primary control survey points, including establishment of pillars.
- Secondary vertical control survey (elevation) tied to the primary control survey points. Can be the same stations as the secondary horizontal control survey points.
- Cross sections (level survey) of the project corridor, including intersections, at suitable intervals not more than 25m apart. Width of survey to cover all proposed works.

The topographical survey will pick up detail of the project corridor including intersections to pick up natural and other features such as roads, buildings, temples, cemeteries, monuments,



property boundaries, natural watercourses, canals, lakes, ponds, swamps, trees, utility lines and installations, quarries etc. For existing roads, the centre line, pavement edge, roadway edge, slopes, drains, bridges etc. shall be picked up. Width of survey shall be adequate to cover all proposed works.

Topographic survey of the proposed bridge sites (on land and shallow water). The topographic survey of the river banks shall be done in sufficient detail to provide contours at 0.25m intervals, bank top and bottom lines, and water level line.

Where the proposed expressway alignment crosses other roads, the survey shall be extended along the other road a minimum of 200m either side of the expressway centerline, and of sufficient width to allow for improvements, including junctions.”

DTM in 2D format will contain all details as noted under the survey scope, spot levels and contours. The DTM in 3D format will follow the CAD standards and give all details as noted under the survey scope, spot levels and contours.

**2.2.2 Geotechnical data in basic design**

The geotechnical investigation for Cao Lanh Bridge Construction Project in the Feasibility Study Stage was carried out by TEDI during October and November 2009 with 16 bore holes and 11 Vane Shear Tests (VST). For the geotechnical report, 14 boreholes drilled in the previous stage have been used. Based on the geotechnical reports, the subsoil condition in the studied area can be rationalised as in the typical profile shown below:

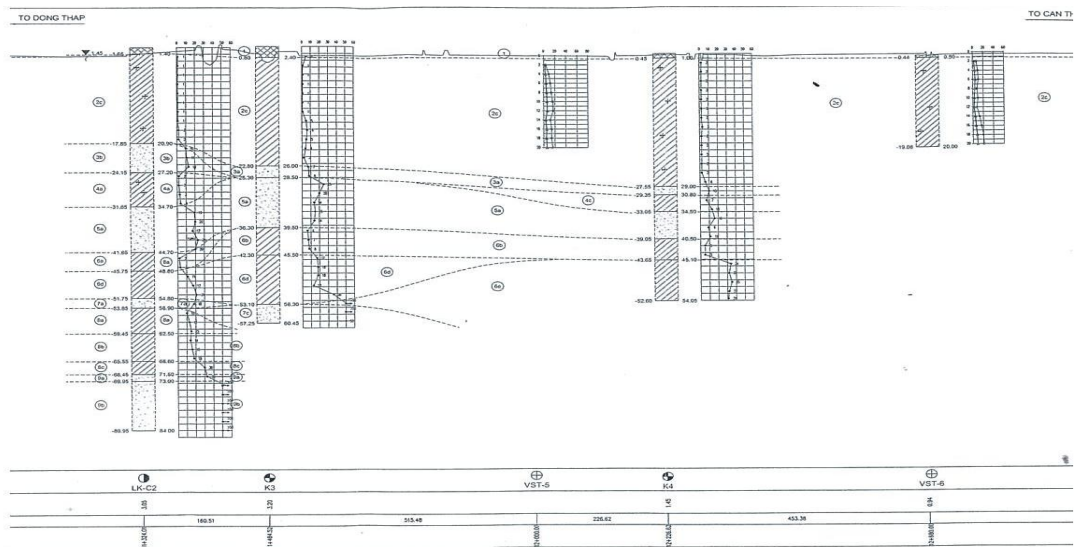

*Typical Subsoil Layer Profile obtained from Borehole information.*

The subsoil layers can be classified as follows:

- Layer 1: Filling soil, Cultivated soil, thickness: 0.25-2.6m, SPT: no test
- Layer 2a: Clay, stiff to very stiff, thickness: 4.25m, SPT: 16 blows
- Layer 2b: Lean clay, medium stiff, thickness: 5.70m, SPT: 4-6
- Layer 2c: Lean clay, Fat clay, very soft to soft, thickness: 3.1~30.5m, SPT: 0~6  
 $S_u : 11.0 \sim 36.5 \text{Kpa}$  (average : 17.67 Kpa)
- Layer 3a: Clayey sand, very loose to medium dense, thickness: 1.0-10.0 m, SPT: 3-10
- Layer 3b: Clayey sand, Silty sand, medium dense, thickness: 1.4-14.7m, SPT: 10-19

Layer 4a: Lean clay, Fat clay, very soft to soft, thickness: 7.1-37.7m, SPT: 0-8  
Layer 4b: Lean clay, Fat clay, medium stiff, thickness: 13.0-23.6m, SPT: 4-8  
Su : 14.5~20.2Kpa (average : 20.2Kpa)  
Layer 5a: Silty sand, Clayey sand, medium dense, thickness: 1.8-11.0m, SPT: 9-28  
Layer 6a: Lean clay, Fat clay, very soft to soft, thickness: 4.1m, SPT: 2-3  
Layer 6b: Lean clay, Fat clay, medium stiff, thickness: 4.6-10.6m, SPT: 5-8  
Layer 6c: Lean clay, Fat clay, stiff, thickness: 3.8-11.5m, SPT: 9-15  
Layer 6d: Lean clay, Fat clay, very stiff, thickness: 1.8-18.5m, SPT: 11-36  
Layer 6e: Lean clay, Fat clay, very stiff, thickness: 4.4-18.5m, SPT: 26-50  
Layer 7a: Poorly graded sand, medium dense, thickness: 2.1-6.3m, SPT: 17-23  
Layer 7b: Poorly graded sand, Silty sand, dense, thickness: 4.2-10.0m, SPT: 32-50  
Layer 7c: Silty sand, very dense, thickness: 4.2-10.0m, SPT: 23-50  
Layer 8a: Lean clay, stiff, thickness: 5.6-6.0m, SPT: 9-15  
Layer 8b: Lean clay, Fat clay, very stiff, thickness: 3.3-10.0m, SPT: 13-32  
Layer 8c: Lean clay, Fat clay, thickness: 2.9m  
Layer 9a: Silty sand, Clayey sand, dense, thickness: 1.5-4.2m, SPT: 31-33  
Layer 9b: Silty sand, Gravel, Silty clayey sand, very dense, thickness: 13m, SPT: 43<N

Analysing subsoil condition, geotechnical profile and laboratory test results, it was found that in the study area that Layers 2 and Layer 4 belong to soft soil group. For these layers the measures of soft soil treatment should be applied during road design process. The geotechnical properties of this soft soil layers can be presented as follows:

- Natural water content: 16.5~82.0 %
- Wet unit weight : 1.46~2.10 g/cm<sup>3</sup>
- Specific gravity : 2.46~2.74
- Liquid Limit : 19.3~88.1
- Plasticity Limit : 14.7~49.8
- Compression index : 0.36~0.8
- Shear strength in shear box test: C = 0.03~0.403 kG/cm<sup>2</sup>,  $\Phi = 20^{\circ}38' \sim 21^{\circ}03'$
- Shear strength in triaxial compression test  
UU : Cu = 0.117~0.318 kG/cm<sup>2</sup>,  $\Phi = 0^{\circ}$   
CU : Cu = 0.106~0.23 kG/cm<sup>2</sup>  $\Phi = 11^{\circ}04' \sim 15^{\circ}04'$

### 2.2.3 Geotechnical Investigation

Based on the result of subsurface investigation conducted during the feasibility study stage and the scope of the Project, the additional geotechnical investigation to be conducted and finalized during the detailed design stage in order to obtain the necessary data for designing each structure on the alignment and determining the depth and distribution area of soft soil layer has been determined. Technically, the geotechnical investigation consisting of drilling, sampling, field testing and laboratory testing, will be complied with in all respects of the technical standards as presented in the previous section.

Geological investigation boring will be carried out as per Item 14.4 in the Vietnamese standards “Motorway survey 22 TCN 263-2000” and standard “Survey of motorway embankment filled on soft soil 22 TCN 262-2000”.

The geotechnical investigation for road and bridge area will be conducted in accordance with following criteria but some changes may be made depending on the site soil conditions.

The geotechnical soil investigation work has already commenced and three contractors have been mobilized to undertake the field work and testing, which is expected to finish by early March 2012.

For the main river piers, 2 boreholes at each pier foundation will be done, one to a depth of 100m below the river bed and the other to 200m below.

For the approach structure piers, of which there will be approximately 36, at least 1 borehole of typically 75m to 90m deep will be made.

The investigations will also include standard penetration testing, in-situ vane shear tests and sampling. Laboratory testing will be carried out to determine the characteristics of the soil material such as the consolidation Tests for the use of designing soil improvement work, shear strength determination for the design of the skin friction and end bearing of the soils.

For bridges and major structures, we are carrying out one borehole per pier or abutment. The boreholes will be extended 10 times the pile diameter below the anticipated pile tip level.

Component 1 – excluding the Cao Lanh Bridge

- 3 bridges, pile depths average 70m pile, 32 piers;
- 1 bridge, pile depths average 45m, 6 piers;
- 3 bridges, pile depths average 40m, 6 piers.

Component 2

- 2 long bridges, pile depths average 70m, 28 piers;
- 5 medium bridges, 44 piers, pile depths average 65m;
- 11 small bridges, 22 piers, pile depths average 60m.

Component 3B

- 2 small bridges, 4 piers, pile depths average 60m;
- 1 medium bridge, 3 piers, pile depths average 70m.

For the bridge locations, the borehole lengths are around 60m to 90m.

For bridge approaches, at least 3 boreholes per approach, each typically 45-50m, all with standard penetration tests.

For road embankments, for about 22km of road, boreholes will go down to 40-60m at 100m intervals, with standard penetration tests and undisturbed soil sampling. Particular attention is given for sampling at ground level where it will be crucial in the consideration of laying the geotextile and the surcharge height for the first lift. Special attention is given to the collection of thin wall undisturbed samples for laboratory testing. This is crucial in the design for soil improvement work for the determination of the design of drain spacing and the time required.

In total we have around 351 nos. of boreholes, 293 nos. on land and 58 nos. in river. We have noticed that the ToR did not have any allowance for soil investigation in the interchange areas. We estimate that another additional 20 nos. boreholes may be needed.

The date of this report approximately 10% of the boreholes has been completed. The three contractors have been mobilized 35 drill rigs and will average 9-10 boreholes completed each day. They are working based on a 7 days work week.

### **2.2.3.1 Road Embankments.**

The road is mainly fill on soft soil embankment. For about 22km of road, the boreholes will be carried out to 40-60m depth at approximately 100m intervals, with standard penetration tests at 300m intervals. The VST will be carry out by 2m per point to depth 20m for all boreholes of road and approach roads.

The number, location, spacing and depth of boreholes have been determined in accordance with the ToR.

### **2.2.3.2 Abutments and Piers of Bridge**

Geological investigation boring will be carried out at all abutments and piers with standard penetration.

Details are as below:

#### **a) Package 1: Cao Lanh Bridge and approach roads.**

##### **Cao Lanh Bridge**

- For the main river piers, 2 boreholes for each pier foundation, one of which will be carried to twice the depth of the foundations. For the purposes, lengths of 100m and approximately 200m below the river bed for each of the two boreholes for each foundation will be carried out.
- For piers of the approach structure piers, it is expected there will be about 34 piers and 2 abutments. One borehole/pier is arranged. The depth of the boreholes will be carried out 75~90m.

##### **Bridges on approach road section (5.7km) includes 7 bridges, in which:**

- Three long bridges (total 32 piers), one borehole/pier is arranged. The depth of the borehole will be carried out at least 70m.
- One medium bridge (total 6 piers), one borehole/pier is arranged. The depth of the borehole will be carried out at least 45m..
- Three bridges (total 6 piers), one borehole/pier is arranged. The depth of the boreholes is expected to be at least 40m.

#### **b) Package 2: Connecting road between Cao Lanh & Vam Cong (15.7km) includes 18 bridges, in which:**

- Two long bridges (total 28 piers), one borehole/pier is arranged. The depth of the borehole will be carried out at least 70m.
- Five medium bridges (total 44 piers), one borehole/pier is arranged. The depth of the borehole will be carried out at least 65m.
- 11 small bridges (total 22 piers), one borehole/pier is arranged. The depth of the borehole will be carried out at least 60m.



**c) Package 3B: Vam Cong Bridge approach:**

- Two small bridges (total 4 piers), one borehole/ pier is arranged. The depth of the borehole will be carried out at least 60m.
- One medium bridges (total 3 piers), one borehole/ pier is arranged. The depth of the borehole will be carried out at least 70m.

**2.2.3.3 Quantities for Geotechnical investigation:**

The following soil investigation works will be executed.

	Investigation Items	Unit	Quant	Note
<b>A</b>	<b>Field work</b>			
1	Waterside boring for road(0-60m)	m	7050	
2	Underwater boring for bridge(0-150m)	m	400	
3	Waterside boring for bridge (0-100m)	m	10272	
4	Waterside boring for bridge(0-60m)	m	2188	
5	Waterside boring for road at bridge end(0-60m)	m	1440	
6	Standard Penetration Test(bridge)	time	6430	
7	Standard Penetration Test(road)	time	4245	
8	Quantity of undisturbed sampling	sample	10657	
9	Site vane shearing test	time	1281	
<b>B</b>	<b>Works of lab test</b>			
	<b>Undisturbed samples</b>			
1	Test to determine physical properties(9 properties)	sample	3739	50% sample
2	Consolidation test(10% of number of test samples)	sample	212	Road and Approach road
3	CU test(5% of number of test samples)	sample	106	Road and Approach road
4	UU test(5% of number of test samples)	sample	106	Road and Approach road
5	qu test(10% of number of test samples)	sample	643	Road and Bridge
	<b>Disturbed samples for cohesionless soil</b>			
1	Test to determine physical properties(7 properties)	sample	1407	50% sample

**2.2.4 River Studies and Bank Protection Work**

**2.2.4.1 General**

The general expectations in respect of the hydraulic modelling/engineering aspects of the Cao Lanh Bridge project are set out in the Terms of Reference, Sections 20 and 21, and are repeated below:

*The Project Preparation Technical Assistance Report (PPTA) included a preliminary study of the Mekong River in the vicinity of the Cao Lanh and Vam Cong bridge sites. This study indicated that the river platform at both bridge locations is relatively stable. However, the study recommended that additional remote sensing data be obtained during the detailed design of the bridges. If the additional data confirm the preliminary study assessment, the design work will need only to ensure the near-bridge morphology is adequately covered. This near-bridge work is included in the scope of the detailed design task for both bridges, for Vam Cong the responsibility of the GOK-financed consultant, and for Cao Lanh for the responsibility of the ADB/AusAID-financed consultant.*

21. *In addition to the near bridge work for Cao Lanh, the ADB/AusAID consultant will undertake a desk study of both river branches and bridge sites, based on the additional remote sensing data recommended in the PPTA study and work undertaken by both consultants during the initial stages of the detailed design assignments for both*

bridges, to confirm the preliminary study assessment. The ADB/AusAID consultant will coordinate this activity with the GOK consultant, and will provide CUU LONG CIPM with a consolidated report for the river in the vicinity of the bridges.

This report will set out the desk study findings, and will recommend additional studies and investigations if necessary. In this event, to ensure that possible river bank impacts and their mitigation are adequately addressed, CUU LONG CIPM will direct both consultants to undertake these additional studies and investigations, under the provisional sum allocations in both contracts. These investigations may include, to be confirmed and defined by the desk study, the following:

- i. a detailed survey of the topography of the river banks and river bathymetry away from the immediate bridge locations, extending up and downstream as necessary;
- ii. a hydraulic and hydrologic measurement program over the wet season, including velocity measurements at critical locations;
- iii. water level measurements and river discharge gauging at two locations several kilometers apart to determine the river energy gradient; and
- iv. Physical and/or numerical modelling of the river banks and possible bank protection works.

Our methodology is to develop a robust model commensurate with the scale of the river system under consideration while making maximum use of existing models, hydrometric and topographic information.

#### **2.2.4.2 River models and hydraulic survey**

Computational hydraulic modelling of a crossing of the scale of the proposed Cao Lanh Bridge across a complex geographical location such as the Mekong Delta requires significant amounts of topographic and hydrometric data.

Our initial consultation of accessible sources of information has revealed that the Mekong Delta has benefited from a large number of hydrological, hydrodynamic, water resources/water balance, economic and related impact assessment models. The hydrodynamic models are of interest here and consist of:

- ISIS model of Tonle Sap Lake and the Mekong Delta developed as part of the Mekong River Commission (MRC)'s Decision support Framework
- Vietnam River System And Plains (VRSAP) model of the Vietnam Delta developed by the Vietnam Sub Institute for Water Resources Planning
- EIA 3D model for the Tonle Sap Lake flood pulse developed as part of the MRC Water Utilisation Programme (MRC/WUP-FIN) funded by the Development Cooperation Department, Ministry for Foreign Affairs, Finland
- MIKE21 model of the Cambodian floodplain developed as part of the MRC Water Utilisation Programme (MRC/WUP-JICA) funded by the Japan International Cooperation Society
- MIKE11 model of Tonle Sap Lake and the Mekong Delta developed as part of the Asian Development Bank funded Nam Theun 2 Hydropower in the Lao People's Democratic Republic (Lao PDR)

The above models point to the existence of river cross sections and floodplain topography although of unknown coverage and quality. We have assumed it will be feasible to obtain the existing models, bathymetric survey, river cross sections and floodplain topography.

### ***Proposed Surveys***

In terms of new survey, we will provide comprehensive Hydrological Survey for the main bridge (Tien River). The survey is subcontracted to a qualified Vietnamese survey contractor. The survey contractor will:

- Establish by bathymetry, the topography of the waterway bed at the proposed Cao Lanh bridge site extending about 3 km upstream and 5 km downstream. This is considered to be adequate for the near bridge studies.
- Collect hydrological and water level information at the project site.

### ***Collection of Digital Topography, Maps & Works Alignment***

Ground topography in a suitable CAD and/or GIS format will be required to represent the floodplain in the lead up to the bridge, as will the spatial alignment of work Components 1, 2 & 3B.

Details of the proposals for Components 1, 2 & 3 are fundamental to the study. As this is the initial stage of the project and details of proposals will not have been developed, **it is assumed that plans, cross-sections and longitudinal sections of the proposed roadway and all bridges/culverts based on the feasibility study will be made available** in a suitable CAD and/or GIS format together with the topographic surveys for the development of the hydraulic models. Details on the drawings of the bridges/culverts should include the proposed elevations/levels of the structure elements (openings, decks, springing/crown levels etc.).

Maps in digital format at the largest scale available will also be required to cover alignment and the extents of the topographic survey.

### ***Hydrometric Data***

Rainfall data will be collected for the Tan Chau, Cho Moi, Cao Lanh and My Thuan rain gauges as well as hourly and monthly maximum, average and minimum water levels at the Tan Chau, Cho Moi, Cao Lanh, Chau Doc and Vam Nau and My Thuan river gauging stations.

## **2.2.4.3 Hydrology**

It is common practice in the planning of major river structures that options are selected for consideration with a view to arriving at a design that will safely pass the flood with a given probability of occurrence in any one year – for instance, the 1% annual probability (100-year return period) flood event. The concept of return period or annual exceedance probability is a convenient basis for examining the flood hydraulics design aspects of the proposed Cao Lanh Bridge. However, this entails estimation of flood flows of a given frequency of occurrence, an undertaking that is likely to be fraught with uncertainty, given the enormous size of the Mekong basin. The depth of hydrological modelling and analysis necessary to derive, say, a basin-wide 100-year flood estimate would certainly be highly challenging and most likely unachievable within the Cao Lanh Bridge project timescale. It is probably in recognition of the complexity of the hydrological behaviour of the Mekong basin that design of river structures tends to be based

on the flood levels of a given probability of occurrence in any one year (as is understood to have been the case with My Thuan Bridge) rather than flows.

Notwithstanding, estimation of scour depths for Cao Lanh Bridge will require velocities and hence design flow inputs to drive the hydraulic model that will be used to compute the velocities. One way of getting round the complexity of deriving flood estimates might be to run the subsequent hydraulic model with say 15-20 years of observed inflows, rainfall and downstream tidal conditions. The number and range of events covered by such model run is arguably large enough to be statistically significant and can form the basis for frequency of occurrence/return period analysis.

At this point it suffices to state that the approach to the hydrological analysis is evolving and ultimately the method adopted will depend on what hydrometric and existing models/modelling information can be obtained.

#### **2.2.4.4 Computational Hydraulic Modelling**

##### ***Existing Models in Context***

As already noted, the Mekong Delta has benefited from a large number of modelling studies in the past that have continually been updated over the years. Given the complexity of the geographical, hydrological and hydraulic complexity of the delta and the relatively short timescale of the modelling aspects of the Cao Lanh Bridge project, development of a completely new computation hydraulic model (even if just near bridge) is likely to prove extremely difficult to achieve. Therefore whilst the existing models are regional in scale and as a consequence, locally coarse, they represent the best starting point (and at the very least would provide boundary conditions) for development of the Cao Lanh Bridge equivalent.

##### ***Modelling Options***

Depending on whether or not existing models can be obtained, there are two modelling options. The first option envisages that the existing models will be made available and in time to enable incorporation of ‘near Cao Lanh Bridge’ detail. The second option would involve construction of a new and independent near bridge model from the ongoing VNC Joint Stock Company’s survey.

Irrespective of which of the above modelling options is subsequently adopted, a linked 1D/2D approach is envisaged ‘near bridge’ and will start with detailed GIS mapping of the spatial alignment of work Components 1, 2 & 3B in order to facilitate conversion to model data. After this, subsequent activities will depend on whether the starting point is one of the existing models or an entirely new ‘near bridge’ model is to be built.

##### ***Near Bridge Modelling (Starting from Existing Model)***

In terms of familiarity with modelling software package and access to expert assistance, the MRC’s 1D ISIS river model would be the preferred option, although we could also make use of the other models. Our method statement assumes that the MRC’s ISIS model will be available.

If starting from the existing MRC 1D ISIS river model, mapping of works alignment will be followed by restructuring VNC’s cross section survey data into the appropriate format and incorporating into the model to capture ‘near bridge’ channel geometry detail.

The indication is that floodplains are represented by overbank flood storage compartments in the MRC 1D ISIS river model that are linked to each other by floodplain connection units and to



the river by spill connections. Therefore the bathymetry of each compartment that is crossed by the works alignment will be re-computed from **floodplain topography that we have assumed will be made available**. The disposition of river/floodplain links (spills) will also be adjusted to enable connection of the new river cross sections to the appropriate floodplain compartments.

Incorporation of new cross sections and adjustments of the floodplain storage compartments crossed by the works alignment will be followed by schematisation of the works itself in 1D, i.e. the main Cao Lanh Bridge and the approach/continuation large, small and irrigation/canal bridges. It is envisaged that the United States Bureau of Public Roads (USBPR) bridge modelling approach (built into the ISIS software package) will be used.

After a period of testing and stabilisation of the updated 1D ISIS model, the 2D element will then be introduced. It is envisaged that the floodplain compartments nearest to the bridge will be converted into 2D floodplain domains using the Two-dimensional Unsteady FLOW (TUFLOW) software developed by BMT/WBM of Australia. The existing geometry of the ISIS 1D river/floodplain spills will be used in the equivalent 1D ISIS/2D TUFLOW links. Similarly, the existing geometry of the ISIS 1D floodplain units will be used in TUFLOW's 2D equivalent to connect adjoining 2D domains.

Assuming that a sufficient freeboard allowance will be available to prevent surcharging of the main bridge opening during the design flood event, the 2D domains from the nearest floodplain compartments will be extended into the river channel. This will enable modelling of the flow, velocity and water level distribution around the piers and across the main opening of bridge and will be achieved using river bathymetry data from the on-going VNC survey and/or from navigation chart data **that it is assumed will be made available in digital format**. If the main bridge span would surcharge during the design event, then it will remain in 1D. Either way, the spans of the approach/continuation large, small and irrigation/canal bridges would remain in 1D.

Recommended practice is at least 4x2D cells across a feature of interest. It would appear that the widths of the openings in the proposed Cao Lanh Bridge (including the bridges underneath the approach and continuation roads) are variable, the smallest being approximately 20m wide. Thus the existing floodplain compartments will be converted to 2D domains of at least 5m grid cells to cover the bridge openings. **We assume that any existing floodplain topography is of at least 5m grid resolution or better, otherwise re-sampling would be necessary.**

#### ***Near Bridge Modelling (Entirely New Model)***

In the event that the existing models cannot be obtained, we envisage that at least boundary conditions can be made available from them for a new and independent near bridge version that is capable of simulating downwater effects from upstream and backwater effects from downstream (tidal effects from the numerous Mekong mouths). This implies quite robust/representative boundary conditions. Ideally the upstream boundary would be at a well defined valley section or at a gauged location and the downstream boundary would be at the estuary. Locating the upstream boundary at a well defined valley section is complicated by the braided nature of the river system in the Mekong basin. The only location where the river system comes together in a single channel is in Phnom Penh, Cambodia. There are gauging stations a short distance south of the Cambodian border at Tan Chau on the Tien River branch and at Chau Doc on the Hau River branch of the Mekong. However, Tan Chau and Chau Doc are

more than 100km from Cao Lanh and for this reason, the survey required to extend the ‘near Cao Lanh Bridge’ model this far upstream would not be cost effective. The upstream boundary of a purely ‘near Cao Lanh Bridge’ model will therefore be dictated by the extents of the VNC survey.

Similarly, given the complex nature of the delta, setting the downstream boundary of a ‘near Cao Lanh Bridge’ model at the estuary would entail embarking on a similarly extensive surveying and modelling effort which (whilst feasible) may not fit with project timescales. The downstream boundary of a purely ‘near Cao Lanh Bridge’ model will therefore also be dictated by the extents of the VNC survey.

The same modelling approach will apply as in the case where the existing MRC ISIS model is available except that an entirely new 1D ISIS river/2D TUFLOW floodplain model will be built although it is assumed that boundary conditions will still come from the existing model(s).

### ***Modelling Outputs***

The output from the model will be time series of flow, water level/depth and velocity distribution across all bridge opening in general and around the abutments, banks and piers of the main bridge in particular, from which peaks, averages and other metrics can be extracted for estimation of such hydraulic effects as scour depths.

### ***Scouring Model***

There are a large number of scour formulae in the literature and those most commonly applied will be used together with the modelled flows, water levels/depths and velocity distribution to estimate a matrix of scour depths from which a view can be taken as to the most applicable.

In parallel, the 1D/2D model will provide boundary conditions for (and be truncated to) a scouring version at the bridge using the United States Army Corps of Engineers’ HEC-RAS software that implements ‘Hydraulic Design Functions’ based on Hydraulic Engineering Circular No.18 (HEC18) of the United States Federal Highway Administration (FHWA). The scour depths from HEC-RAS will then be compared with those estimated from other formulae using the modelled flows, water levels/depths and velocity distribution as stated above in order to place both sets of scour estimates in context.

### ***Closing Remark***

As in the case of hydrological analysis, it suffices at this point to state that the approach to computational hydraulic modelling is evolving and ultimately the method adopted will depend on what hydrometric and existing models/modelling information can be obtained.

## **2.2.5 Geomorphology**

### **2.2.5.1 Background**

The Tien River is one of the principal tributaries of the Mekong flowing over ancient deltaic deposits with the bed and banks characterised by more recent fluvial/marine/swamp sediments mostly of clays and fine sands.

Previous inspection of the Tien River in the vicinity of the proposed Cao Lanh Bridge concluded that general erosional activity was low being confined to local collapse of the silt and clay composite banks. More significant areas were noted around My Luong and Tan Thuan upstream

and accretion upstream of Ong Ho Island. The erosion appears linked to bank sedimentology, vegetation and the presence of bank protection. More significant change has been recorded further downstream (My Thuan) and a groyne field is in place to control this. Aerial photograph analysis show erosion and deposition associated with the islands upstream of Cao Lanh, however the study only utilised imagery through to 2004.

These studies suggest that Cao Lanh Bridge is likely to impact on sediment transport and river dynamics local to the structure and more widely up and downstream. Similarly river dynamics up and downstream of the bridge will impact on local river response to the structure. As such a geomorphological audit is required at two scales (local and regional) linked to a more general understanding of sediment transfer along the Mekong and distributary channel behaviour across the delta.

### **2.2.5.2 Local Geomorphological audit of Cao Lanh Bridge**

#### ***Survey area***

In line with the Terms Of reference the river immediately up and downstream of the proposed bridge crossing will be surveyed covering the same area as the hydraulic modelling.

#### ***Survey methodology***

The quantitative modelling will require bathymetric survey and sediment survey.

Qualitative local audit linked to the results of the local hydraulic modelling and HEC 18 studies allowing the geomorphological study to also focus on river scour linked to the bridge. Bridge measurements will be utilised alongside outputs from the 1D hydraulic model to estimate contraction scour, pier scour and abutment scour. It will also consider potential footing scour and pressure flow scour under extreme flows. These predictions will be compared to measurements of scour for other bridges in the area where these data are available.

Data requirements for the Local Geomorphological audit of Cao Lanh Bridge

- Outputs from the hydraulic model survey
- Local historic bathymetric survey data
- Sediment sampling and grade analysis
- Data on scour at other bridges across the region

### **2.2.5.3 Regional Geomorphological audit linked to Cao Lanh Bridge**

#### ***Survey area***

Qualitative process based survey of the watercourses up and downstream of the proposed bridge structure will incorporate the Tan Thuan Dong island complex upstream and extending downstream to cover the sedimentation issues reported around Ong Ho Island and the groyne field in the vicinity of My Thuan. Visits will also be made to the secondary crossing sites along the proposed link road south to the Vam Cong Bridge to assess the geomorphological condition and likely dynamics of the watercourses present.

#### ***Survey methodology***

A qualitative audit of the dynamic geomorphology of the Tien River will be undertaken from a boat and compared with earlier survey findings and wider understanding of the sediment dynamics of the system.

Collation and review of archive aerial imagery for the river.

Data requirements for the Regional Geomorphological audit linked to Cao Lanh Bridge

- Wider historic bathymetric survey data
- Sediment sampling and grade analysis or previous sample results
- Aerial imagery
- LIDAR data
- Scour data from other bridges in the region.

#### **2.2.5.4 Study outputs**

The survey data will facilitate 1D and potentially 2D numerical modelling of the reach upstream and downstream of the proposed bridge. Recorded flow patterns derived from the velocity data will allow identification of flow convergence and divergence linked to potential erosion and sedimentation. The 1D ISIS model will be able to utilise the DEM of the data to extract detailed cross-sectional information for the immediate bridge site and hydraulic outputs from this model can be related to the potential for erosion/deposition and channel change.

The data lends itself to 2D modelling of the local hydraulics (using River 2D or similar software) further refining the ADVP flow magnitude and direction analysis to model a range of flow effects at the site. It would also allow a dynamic bed model to be developed for the site (the CAESAR model for example) which could simulate the effects of the bridge and associated works on the morphology under the current and climate changed flow regime to identify likely areas of instability along the extended survey reach.

Preliminary suggestions regarding any mitigation works will be made based on the study results. This will lead to preparation of options for scour protection works of the bridge.

#### **2.2.5.5 Climate change**

The impact of climate change on the Mekong Delta is expected to be significant and needs to be taken into account in the bridge and road design. The hydraulic analysis will take into account:

- Changes in peak water levels due to changing fluvial flows and sea level rise
- Changes in velocity
- Possible long term geomorphological impacts of sea level rise on channel geometry and regime width
- Possible impacts of climate change adaptation measures such as raising of banks to protect

The available guidance on expected and extreme scenarios of climate change for Vietnam and for regional changes in flow (such as that produced by MRC and ADB) will be used in the modelling and sensitivity tests carried out. It is envisaged that the regional model of the Mekong delta will be used so that changes at the coast can be transferred to give expected changes at the Cao Lanh Bridge and road locations.

For geomorphological studies the regime of the river will be analysed taking account of likely changes in regime considering both tidal prism and dominant fluvial flows and how these relate to regime section area and channel width.

Reference is also made to Section 3.11 of this report which also comments on Climate Change.

### **2.2.5.6 Risk related to River Studies**

Near bridge study of the Vam Cong Bridge is the responsibility of the GOK-financed consultant. In accordance with the TOR and clarifications received, the study for Vam Cong Bridge should be carried out in parallel to the hydraulic studies of Cao Lanh Bridge.

However, the consultant for Vam Cong Bridge has not yet been contracted, and therefore the proposed time schedule of the desk study may not be possible to achieve.

Any delay in near bridge studies may have an effect on the overall time schedule of the project. If the near bridge studies for Vam Cong Bridge are not carried out in time:

- a) The desk study for both river branches will be delayed
- b) If the conclusion of the desk study is, that additional hydraulic investigations and studies are necessary, these studies may not be concluded before the projected end of the design period (September 2012)
- c) The design of possible river bank protection works, and contracting of those works would be delayed

In order to keep the time schedule of the project, we expect that the near bridge surveys and hydraulic studies for the Vam Cong bridge should be started latest in January 2012.

## **2.3 Highways and Interchanges**

### **2.3.1 Design Standards and Criteria**

Based on design specification and Vietnamese expressway network plan up to 2020 approved by the Prime Minister and the plan of Ho Chi Minh; a type A-Expressway with design speed of 80km/h is proposed which will be designed to Vietnamese Highway Design Standards (TCVN5729-1997). These will be supplemented by recognized international standards, such as US/UK/Australian standards, if necessary.

Taking into consideration the Feasibility Study (FS), the Project Preparation Technical Assistance (PPTA) Report, and international standards, the Consultant will prepare a paper on design criteria which will be presented for discussion and agreement.

### **2.3.2 Cross-Sectional Design**

The cross-sectional design of the Expressway Components has been covered in the FS. Also, the ToR makes reference to the PPTA Report which states the following:

- The Project will be built in two stages.
- In Stage 1, the expressway and bridges will be built to four lanes with a central median, and the two cable-stayed bridges (Cao Lanh and Vam Cong) will be built to six lanes to accommodate future expansion.



- Stage 2 (future) comprises the widening of the expressway and bridges (other than the two cable-stayed bridges which are constructed to full six-lane width in Stage 1) to full six-lane expressway standard.

It is commented that the Vam Cong cable-stayed bridge and its approach structures are not part of these consultancy services.

Based on the FS and PPTA Report, and supplemented by international standards, the typical cross-sections of the main components will be developed and presented, as part of the paper on design criteria, for discussion and agreement. The typical cross-sections will cover the following:

- The expressway.
- The expressway bridges other than the Cao Lanh cable-stayed bridge.
- Approach structures to Cao Lanh cable-stayed bridge.
- Ramps of the Interchanges.
- Collector road between QL80 and QL54.

### 2.3.3 Alignment Design

A critical aspect of modern design of highways is the choice of software. MXROAD and InRoads are two widely used highway design software. Both these are propriety products of Bentley, the leading highway design software company. Both MXROAD and InRoads are powerful 3D road design software tools. The 3D capabilities allow the designer to easily optimize the designs. It is proposed to use either MXROAD or InRoads for the highway design. For the drafting platform, AUTOCAD is proposed.

The use of the above-noted software will facilitate better coordination with and integration of other components of design, such as structures, drainage, lighting etc, with the highway design.

The alignment design will be carried out in full compliance with TCVN 5729-1997 supplemented by international standards and additional detailed criteria as necessary. The CMDCP is ranked as a Level A Expressway on the basis of projected traffic volume, with a design speed 80 km/hr. The design center-line is located at the middle of the central separator, based on the ultimate completion phase.

As noted above, the Consultant will employ proprietary highway design software to create the basic alignment model. Initially this will comprise the Expressway carriageways and the model, created by the Highway Design Team will be distributed amongst the other design teams. This will allow the other teams working on the designs to embark on their key work activities simultaneously at the earliest possible stage in the knowledge that all teams are working to accurate and identical data.

Subsequently the model will be updated as necessary taking into consideration feedback from the teams handling the various aspects such as structures, drainage, geotechnical etc., and distributed to the various project teams on a periodic basis. This will ensure all teams involved in the design are working on up-to-date and consistent data. This approach will avoid any basic layout errors being translated to detailed design works and ensure that the new works, as designed, are a precise match to the actual features on the ground and correctly inter-relate both with each other and the existing conditions. The Consultant will ensure that the basic

highway alignment is designed, reviewed and finalized early so that critical activities, such as cable-stayed bridge design, can proceed unhindered and in the certainty that their basic geometry will not change.

As the existing ground is flat, the proposed longitudinal grade for the most part will be less than 0.5%. A flat longitudinal grade is feasible as the carriageway edges will not have kerbs which hinder lateral drainage of the pavement surface.

As the expressway is mostly on embankment, it will be possible to have bridge approaches with mild longitudinal gradients to effectively cater to the higher finished levels of the bridges. Such mild longitudinal gradients will be well within acceptable limits. It is commented that the US standards recommend a maximum grade of 4% for freeways in flat terrain.

The FS states that a 739m length of expressway section (in the stretch that does not include the cable stayed bridges) requires a longitudinal grade greater than 4%. This aspect will be reviewed with a view to reducing the grade, should the length of grade be excessive. Long grades in excess of 4% will induce excessive speed reductions in trucks.

#### 2.3.4 Intersection Design

The location and type of interchanges are given in the FS. The configurations and the precise layouts will be confirmed during the Engineering Master Plan activity.

There are four interchanges planned:

- Interchange of NH30 at Km0+329: intersection of 4-way junction between the expressway and NH30.
- Interchange of PR849 at Km7+396: intersection of 4-way junction between the expressway and PR849.
- Interchange of QL80 at Km18+787.79: intersection of three-way junction between the expressway and QL80.
- Interchange of QL54 at Km23+760.52: intersection of three-way junction between the expressway and QL54.

These four interchanges are designed as incomplete clover-leaf interchanges with 2 ramps. The concept of the interchanges as given in the FS will be reviewed and refined based on physical conditions of the site.

The preliminary designs of each interchange will be completed by the Highway Design Team, following a full review of configuration and layout, and these designs will be presented at Engineering Master Plan stage. The subsequent layouts, if agreed, will be issued as detailed models to the relevant Project Design teams for immediate progress on other design elements. The Highways Team will then proceed to finalize the detailed designs. This process will almost exclusively comprise the production of Tender Drawings with only the addition of geometric data and descriptive notes being required. Should further minor adjustments to layouts and geometry prove necessary for any reason, these adjustments will be incorporated back into the model and redistributed to the other Design Teams.

## **2.3.5 Embankment Design**

### **2.3.5.1 Soft Ground**

The expressway alignment traverses soft ground.

Soft ground may require a range of treatments to deal with the varying thicknesses of highly compressible soft clay. These techniques may include surcharge, overfilling, sand columns, wick drains, reinforced piled slabs and geotextile mesh and fabric enhancements.

To be able to accurately predict the settlement during construction and the residual settlement after the project completion is a crucial part of the soft soil treatment design. It is important that reliable soil parameters are obtained from geotechnical investigations for the soft ground consolidation design.

Methods of soft ground treatment are discussed elsewhere in this Inception Report.

### **2.3.5.2 Embankment**

Embankment design as outlined in the FS comprises sand fill with cohesive material on the side slopes to contain/protect the sand fill. The FS proposes side slopes of 1V:2H for the ultimate stage, i.e. Stage 2 and 1V:1.5H for Stage 1 construction. The FS proposed side slopes will be reviewed based on the findings of the proposed soil investigation and appropriate changes made where necessary.

It is commented that the soft ground improvement measures may need to be carried out to cover Stage 2 as well. Given that the techniques may likely involve surcharge loads, it may be cost-effective to construct in Stage 1, the whole of the embankment covering Stage 2. This aspect will be further studied and recommendations made for consideration and approval.

## **2.3.6 Pavement Design**

Based on the classified traffic projections in the FS, the traffic loading for purposes of pavement design will be estimated. Pavement designs will follow the Vietnamese Pavement Design Standards, supplemented as necessary by internationally recognized codes and guidelines.

Soft ground conditions prevail through the majority of the Project. It is of particular note that Continuously Reinforced Concrete Pavement (CRCP) is highly suited to such conditions and is recommended in Western countries and in the US for adoption in areas of particularly soft ground. This pavement type has a much larger percentage of longitudinal reinforcing steel than a traditional rigid pavement slab (typically 0.5% of cross-sectional area).

CRCP has not gained widespread popularity in Asia but it was first constructed in Thailand in 1999 on a high capacity Urban Expressway and has performed excellently. This pavement design case can be closely compared with adjacent highways that were designed and constructed to national highway standards but which have performed poorly and have seen subsequent to settlement, cracking of slabs, total failure and constant repair. CRCP, although more expensive in initial capital outlay, is ideally suited to soft ground conditions and is perfectly suited to a project where much of the project is on viaduct but with long lengths of discrete at-grade road sections. The success of any pavement is judged by its whole life performance, its integrity, and its ride quality and the design and detailing of transition sections between viaducts and at-grade sections, especially on a high speed Expressway, is crucial to this success.

With due regard to above, a life-cycle cost analysis will be made for CRCP and Asphaltic Concrete (AC) pavements.

### **2.3.7 Drainage Design**

The drainage design will be carried out in accordance with Vietnamese Standards, supplemented with recognized international standards, guidelines and best practices. It is noted that the Project is almost exclusively across environmentally sensitive areas. Careful attention will be paid to the interaction with, and the effect on, existing drainage systems. Positive drainage may be recommended, using piped systems. Free flow drainage (or free-fall) from viaducts may not be suitable at any point along the alignment but these key aspects will be reviewed and reconfirmed early.

The barrier effect of embankments on existing flow patterns will have major significance. The Consultant will pay considerable attention to the manner in which such flow paths remain unaltered at a minimum, and ideally seek ways in which existing flow patterns can be improved and enhanced. The Drainage Design team will receive the Highways Model in digital format and proceed to carry out runoff and hydraulic calculations, adopting a compatible suite of programs. Output will comprise a series of Drainage Layout drawings and standard drainage details based on current Vietnamese Expressway designs. Any improvements to the standard details that the Consultant considers advantageous will be proposed. Any such improvements would be compatible with locally available materials, skills and sources of supply.

### **2.3.8 Street Furniture and Roadside Features**

Street Furniture and Roadside Features will be designed to (a) ensure the safety road users and Expressway maintenance personnel and (b) project a unified Expressway identity which is to the highest Vietnamese and international standards.

This aspect of highway design is often relegated in importance but is a critical final phase of the highway design process and will be carried out by the international and local Highway Engineers under the close supervision of the Highways Team Leader and in close consultation with senior counterpart staff from MOT/ CUU LONG CIPM .

### **2.3.9 Road Safety**

The Consultant will optimize the road safety features of the Expressway. Close attention will be paid to significant road safety features and finally a design audit of the highway design and facilities will be taken on completion of the design stage. The specification of any additional roadside safety equipment such as warning signs, delineators, and illuminations will be based on the outputs of this road safety design audit. This work will be undertaken in accordance with the ADB's guidelines on road safety audits - ADB 2003, Road Safety Audit for Road Projects - An Operational Toolkit. This work will also include proper traffic safety system (road marking, sign board, guard rail, etc.) in accordance with the Vietnamese standard 22TCN 273-01.

## **2.4 Bridges on the Project**

### **2.4.1 General**

The project consists of in total 6,201 m of bridges. The main bridge in the project is the Cao Lanh Cable-Stayed Bridge. The total length of the bridge is 2,026.8 m. The span lengths of the cable

stayed part are 5.0 m + 150.0 m + 350.0 m + 150.0 m + 5.0 m. The second longest bridge is Lap Vo Bridge. The bridge has a free cantilever bridge section over the river Lap Vo. The total length of the bridge is 603.4 m. The spans of the free cantilever bridge are 47.0 m + 72.0 m + 47.0 m.

The total number of the bridges in the project is 27 and in addition there are two independent underpass culverts and several drainage culverts.

Five small size bridges include underpass-bridge configurations which are integrated into the abutment structures.

Cao Lanh cable-stayed bridge is a concrete structure. The superstructures of all other bridges use prefabricated element bridge types. The underpass-bridges are cast in-situ structures.

Bridges are founded either on cast in-situ bored piles, diameters 1.0 m and 1.5 m, or on driven piles 450x450 mm<sup>2</sup> depending on their size.

The bridges will have transition slabs to minimize settlement problems that may cause discomfort or dangerous conditions for vehicle occupants.

## 2.4.2 2.4.2 Basic Concepts of the bridges

The project in the Feasibility Study includes three components:

Component 1 includes 6 small or medium size bridges and Cao Lanh cable-stayed bridge.

- The basic design concept for these bridges uses 40 m span pre-fabricated Super-T40 superstructure, or 24 m span hollow girder S24 standard element superstructure.
- Cao Lanh Bridge comprises a cable-stayed bridge and approach bridges. The cable-stayed has a main span of 350 m and back spans of 150 m. The approach bridges generally comprise 17 spans Super-T40 superstructure on each side.

Component 2 includes 17 small or medium span bridges. The basic design concepts use prefabricated elements: Super-T40, I33, S24 and S21. For Lap Vo Bridge, the FS design uses free cantilever bridge, which consists 3 spans of 47 m + 72 m + 47 m over the river and the approach bridges on each side use the Super-T40 bridge system.

Component 3B includes 3 small size bridges. The basic design concept uses the prefabricated standard voided slab bridge type S24.

Total sum of span lengths of the small or medium size bridges is 3891.0 m and the sum of the span lengths of approach bridges in Cao Lanh Bridge is 1354.8 m.

## 2.5 Small/Medium Bridges and Cable Stay Bridge Approaches

### 2.5.1 Design Standards and Criteria

The works will be designed in accordance with the AASHTO LRFD Bridge Design Specifications SI Units 4th Edition, 2007 with 2008 interim revisions (hereinafter referred to as “AASHTO”) except for the following:

- Live loading will not be less than HL-93 as defined in the Vietnamese Bridge Design Code, 22TCN-272-05.
- Pile foundation – in accordance with design specification 22TCN 205-1998.



- Wind load – in accordance with TCVN 2737-1995.
- Seismic effects are in accordance with TCXDVN 375-2006. The Earthquake Grade 7 is applied for the bridges located in Lai Vung and Lap Vo Districts.

**2.5.1.1 Dead Loads**

Dead loads include concrete, steel reinforcement, prestressing tendons and any other embedded components or the weight of overburden, based on the following unit weights:

• Reinforced Concrete	25.0 kN/m <sup>3</sup>
• Asphaltic Concrete	22.5 kN/m <sup>3</sup>
• Steelwork	78.5 kN/m <sup>3</sup>
• Soil, compacted sand, silt or clay	18.0 kN/m <sup>3</sup>
• Water	10.0 kN/m <sup>3</sup>

**2.5.1.2 Superimposed Dead Loads**

Superimposed dead loads have been calculated in accordance with the AASHTO LRFD Bridge Design Specification. Loads include the effects of utilities, waterproof membrane, road surfacing and non-composite barriers.

Bridge surfacing used shall be 70mm asphaltic concrete but allowance for 100mm thickness is made in the design.

**2.5.1.3 Live Loads**

Traffic Loads

Vehicular loading on bridges, designated HL-93, consists of a combination of the:

- Design truck or design tandem and
- Design lane loading.

Each design lane under consideration is occupied by either the design truck or tandem coincident with the lane load where applicable. The loads are assumed to occupy a width of 3.0 m transversely within a design lane.

Design Truck Loading

The weights and spacing of axles and wheels for the design truck are as specified in Figure 1. The spacing between the two 145 kN axles is varied between 4.3 m and 9.0 m to produce the maximum effects.

Design Tandem Loading

The design tandem consists of a pair of 110 kN axles spaced 1.2m apart. The transverse spacing of the wheels for both loadings has been taken as 1.8m.

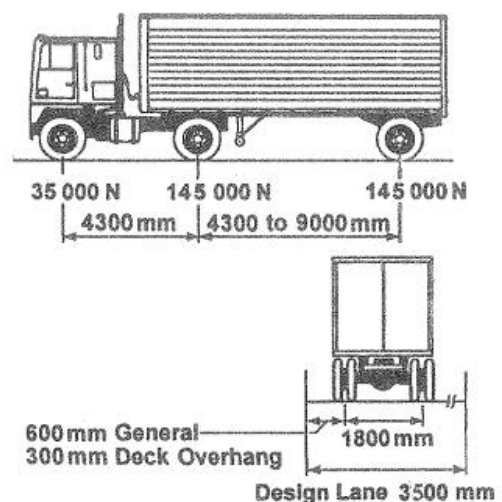

**Figure: Characteristics of the Design Truck**Design Lane Loading

The design lane load consists of a load of 9.3 kN/m uniformly distributed in the longitudinal direction. Transversely the design lane load was assumed to be uniformly distributed over a 3.0 m width. The force effects from the design lane load are not subject to a dynamic load allowance.

The bridge will be designed:

- a) To resist the traffic loads specified below which approximate the effects induced by moving traffic, stationary lanes of traffic and pedestrian traffic.
- b) For the most adverse effects induced by the following loading elements, combinations of these elements and their corresponding load factors:
  - (i) Design truck load
  - (ii) Design tandem load
  - (iii) Design lane load
  - (iv) Dynamic load allowance (IM)
  - (v) Number and position of traffic lanes
  - (vi) Multiple presence factors (m)
  - (vii) Centrifugal forces (CE)
  - (viii) Braking forces (BR)
  - (ix) Fatigue load
  - (x) Pedestrian load (PL).
  - (xi) Motorcycle load

Multiple Presence Factors (m)

The live load force effect will be determined by considering each possible combination of number of loaded lanes multiplied by a corresponding multiple presence factor to account for the probability of simultaneous lane occupation by the design live load.

Number of Loaded Lanes	Multiple Presence Factor, m
1	1.20
2	1.00
3	0.85
>3	0.65

**MULTIPLE PRESENCE FACTORS**

The number of standard design lanes loaded and the load patterning (standard design lane numbering) has been selected to produce the most adverse effects.

Number of Traffic Lanes

The Cao Lanh Bridge will use 6 lanes in the design. Lap Vo Bridge has 6 traffic lanes. All the others have 4 traffic lanes.

Dynamic Load Allowance (IM)General

The dynamic load allowance, IM, has been specified as a proportion of the design truck or tandem load defined below. The dynamic load allowance is not included for centrifugal or braking effects nor is it applied to pedestrian loads or to the design lane load.

#### *Magnitude*

The dynamic load allowance factor to be applied to the static load of the design truck or tandem has been taken as  $(1 + IM/100)$ .

The value of IM for the appropriate loading has been as given as follows:

**Dynamic Load Allowance IM**

Component	Dynamic load allowance, IM
Deck Joints – All Limit States	75%
All Other Components	
• Fatigue & Fracture Limit State	15%
• All Other Limit States	25%

#### *Application*

The dynamic load allowance will be applied to all parts of the structure extending down to the ground line.

For parts of the structure below the ground line, the dynamic load allowance in per cent will be taken as:

$$IM = 33 (1.0 - 4.1 \times 10^{-4} DE) \geq 0\%$$

Where DE is the minimum depth of earth cover in millimetres.

#### Horizontal forces

##### *Centrifugal forces (CE)*

For bridges on horizontal curves, allowance has been made for the centrifugal effects of traffic load on all parts of the structure. The bridge will be designed to resist the most adverse effects induced by the HL-93 loading and the centrifugal force.

Centrifugal force has been taken as the product of the axle weights of the design truck or tandem and the factor C, taken as:

$$C = \frac{4v^2}{3rg}$$

Where:

v = the highway design speed (m/sec) = 80 km/hr

r = the radius of curve (m)

g = the acceleration due to gravity (9.81 m/s<sup>2</sup>).

##### *Braking forces (BR)*

Braking effects of traffic will be considered as a longitudinal force and have been applied in either longitudinal direction. The restraint system will be designed to resist the most adverse co-existing effects induced by the braking force and the vertical traffic load. The braking force will be applied in accordance with the distribution of mass of the vertical traffic load.

The braking force is assumed to act horizontally at a distance of 1.8 m above the roadway surface and is taken as 25 percent of the axle weights of the design truck or design tandem. Multiple presence factors apply.

The number of lanes to be included will be limited to those likely to carry traffic in a single direction, unless specified otherwise by the relevant authority.

When assessing the effects of longitudinal forces on bridge bearings and substructures, the friction or shear displacement characteristics of expansion bearings and the stiffness of the substructure will be taken into account.

#### Pedestrian Loads

Footways will be designed for a load of 3.0 kN/m<sup>2</sup>.

The loaded area is the area related to the structural element under consideration.

Dynamic load allowance need not be applied to pedestrian loading.

#### Motorcycle Loads

Traffic lanes on the bridges that are designated for motorcycles will be designed for a load of 5.0 kN/m<sup>2</sup>.

The loaded area is the area related to the structural element under consideration.

Dynamic load allowance will not be applied to motorcycle load.

#### **2.5.1.4 Earthquake Load**

Earthquake design is in accordance with TCXDVN 375-2006. The Earthquake Grade 7 is applied for the bridges located in Lai Vung and Lap Vo Districts.

#### **2.5.1.5 Vehicle Collision Loads on Barriers**

The effects of barrier design loads will be assessed in accordance with Section 13 of AASHTO LRFD Bridge Design Specification.

#### **2.5.1.6 Vehicle Collision Loads on Piers**

The bridge piers located within 9 m to the edge of the roadway will be designed to resist a 1.8 MN impact load in accordance with cl. 3.6.5.2 of 22TCN 272-05.

#### **2.5.1.7 Wind Loading**

Wind loads will be determined in accordance with the Vietnamese Bridge Design Code.

Vietnamese Standard TCVN 2737-1995 indicates that the wind zone for the project is Zone I.A. This correlates to a basic 3 second gust wind velocity with 100 year return period of 32 m/s.

For the STRENGTH III load combination, the design wind load has been applied to both structure and vehicles. Transverse wind load on vehicles have been represented by a line load of 1.5kN/m acting horizontally, transverse to the longitudinal centerline of the structure and 1.8 m above the carriageway. Longitudinal wind load on vehicles is represented by a line load of 0.75 kN/m, acting horizontally, parallel to the longitudinal centerline of the structure and 1.8 m above the carriageway. In each case the load has been transmitted to the structure.

Longitudinal and transverse wind loads on vehicles are applied as separate load cases.

#### **2.5.1.8 Temperature Effects**

Temperature variation between +10°C to +47°C according to 22TCN-272-05. The long term average bridge temperature adopted is 27°C.

Differential temperature gradient effects will be determined in accordance with 22TCN 272-05 with temperature gradients from the Vietnamese Bridge Design Code and the following design values have been adopted:

Positive temperature gradient = 23°C

Negative temperature gradient = - 7°C

#### **2.5.1.9 Differential Settlement**

The bridge superstructure shall be designed for differential settlement between supports consistent with the final choice of foundations. Differential settlement will be limited to a maximum of 20 mm

#### **2.5.1.10 Ship Impact Load against piers**

The Cao Lanh Bridge approach bridge piers will be designed to withstand the ship impact load defined in Clause 3.14.11 of 22TCN 272-05 based on a 1000 DWT vessel with a speed of 2m/s + xx m/s as an ultimate load.

The Lap Vo Bridge piers will be designed to withstand the ship impact load defined in Clause 3.14.11 of 22TCN 272-05 based on a 300 DWT vessel with a speed of 2m/s + xx m/s as an ultimate load.

Other bridge piers have navigational clearance 20x3.5 m, will be designed to withstand the ship impact load defined in Clause 3.14.11 of 22TCN 272-05 based on a 100 DWT vessel with a speed of 2m/s + xx m/s as an ultimate load.

#### **2.5.1.11 Load Case Combinations**

##### Classification of loads and load effects

Loads and load effects are divided into permanent effects and transient effects.

##### *Permanent effects*

Permanent effects include the following:

1. Dead load of structural components and non-structural attachments (DC);
2. Dead load of wearing surface and utilities (DW);
3. Horizontal earth pressure load (EH);
4. Accumulated locked-in force effects resulting from the construction process (EL);



5. Earth surcharge load (ES);
6. Vertical pressure from dead load of earth fill (EV).

*Transient effects*

Transient effects include the following:

1. Vehicular braking force (BR);
2. Vehicular centrifugal force (CE);
3. Creep (CR);
4. Vehicular collision force (CT);
5. Vessel collision (CV);
6. Earthquake (EQ);
7. Friction (FR);
8. Vehicular dynamic allowance (IM);
9. Vehicular live load (LL);
10. Live load surcharge (LS);
11. Pedestrian live load (PL);
12. Settlement (SE);
13. Shrinkage (SH);
14. Temperature gradient (TG);
15. Uniform temperature (TU);
16. Wind on live load (WL);
17. Wind load on structure (WS).

*Load combinations*

The load factors for various loads comprising a design load combination are as follows:

	Limit State	Load Combination	WS	WL	FR	TU CR SH	TG	SE	EQ	CT CV
Strength I	$\gamma_p$	1.75	-	-	1.00	0.50/1.20	$\gamma_{TG}$	$\gamma_{SE}$	-	-
Strength II	$\gamma_p$	1.35	-	-	1.00	0.50/1.20	$\gamma_{TG}$	$\gamma_{SE}$	-	-
Strength III	$\gamma_p$	-	1.40	-	1.00	0.50/1.20	$\gamma_{TG}$	$\gamma_{SE}$	-	-
Strength IV EH, EV, ES, DW DC only	$\gamma_p$ 1.5	-	-	-	1.00	0.50/1.20	-	-	-	-
Strength V	$\gamma_p$	1.35	0.40	1.00	1.00	0.50/1.20	$\gamma_{TG}$	$\gamma_{SE}$	-	-
Extreme Event I	$\gamma_p$	$\gamma_{EQ}$	-	-	1.00	-	-	-	1.00	1.00
Extreme Event II	$\gamma_p$	0.50	-	-	1.00	-	-	-	-	-
Service I	1.00	1.00	0.30	1.00	1.00	1.00/1.20	$\gamma_{TG}$	$\gamma_{SE}$	-	-
Service II	1.00	1.30	-	-	1.00	1.00/1.20	-	-	-	-
Service III	1.00	0.80	-	-	1.00	1.00/1.20	$\gamma_{TG}$	$\gamma_{SE}$	-	-
Service IV	1.00	-	0.70	-	1.00	1.00/1.20	-	1.00	-	-
Service combination for segmentally constructed bridges	1.00	-	1.00	-	-	-	1.00	1.00	-	-
Fatigue – LL, IM & CE only		0.75	-	-	-	-	-	-	-	-

Load Factors for Permanent Loads,  $\gamma_p$

Type of Load	Load factor		
	Maximum	Minimum	
DC: Dead load component & attachments	1.25	0.90	
DW: Dead load wearing surfaces & utilities	1.50	0.65	
EH: Horizontal Earth Pressure	Active	1.50	0.90
	At-rest	1.35	0.90
EL: Locked-in erection stresses	1.00	1.00	
EV: Vertical earth pressure	Overall stability	1.00	N/A
	Retaining walls and abutments	1.35	1.00
	Rigid buried structure	1.30	0.90
	ES: Earth surcharge	1.50	0.75

The load factor for temperature gradient,  $\gamma_{TG}$ , shall be taken as 1.0 for both ULS and SLS when live load is not considered. When live load is considered, the load factor shall be 0.5 for both ULS and SLS.

The load factor for settlement,  $\gamma_{SE}$ , shall be taken as 1 for both ULS and SLS.

## 2.5.2 Bridges types identified in the Feasibility Study

### 2.5.2.1 Super-T Bridges

The project includes 5 bridges of this type and also the approaches of the Cao Lanh bridge using generally 40 m span Super-T girders. The Super-T cross section is widely used in Vietnam and has shown its advantages in relative low cost and fast construction technology. The pier cross head is hidden in the structure. The fabrication of the girder needs careful installation of reinforcement and strands as well as skilled concreting technology and careful handling of the girders during transportation and erection.

A grillage model for analyzing will be used to determine the vertical load distribution to the individual Super-T girder and bearings. Vertical loads comprise self-weight, superimposed loads and live loads.

The Super-T girder will be subjected to loadings in stages. These stages are:

- At transfer and girder installed on bearings
- When the deck slab is cast
- In service at a time approaching infinity.

The bridge system can form an integral bridge system using continuous deck slab. Link slabs are provided between the adjacent spans within each module to achieve a continuous surface for vehicles. Link slabs allows the vertical rotation of the main girders and transfer sudden loads such as horizontal longitudinal braking force and seismic forces to piers.

In the Cao Lanh approach bridges more than five spans will be linked together.

### 2.5.2.2 I-girder Bridges

The project includes 5 bridges utilizing I33 girders. In two of the voided slab bridges there is a

middle span which uses I33 girders causing the change in structural depth of the superstructure.

This bridge type is widely used in Vietnam. The structural analysis follows the same method as for Super-T40 bridges. All the spans act as simply supported girders. The expansion is taken at each support. The bearings are elastomeric bearings.

**2.5.2.3 Voided Slab Bridges**

The project includes 5 bridges utilizing voided slab type S21 and 13 bridges of voided slab type S24.

This bridge type is widely used in Vietnam. The structural analysis follows the same method as for I 33 bridges. All the spans act as simple supported girders. The expansion is taken at each support. The bearings are elastomeric bearings.

**2.5.2.4 Underpass Culverts**

Underpass culverts are cast insitu concrete box structures founded on driven piles. One underpass culvert will work as drainage culvert as well. The water runs under the floor slab of the underpass in its own box. A couple of underpass culverts are integrated to the abutments of voided slab bridges.

**2.5.2.5 Free cantilever Bridge**

The cast insitu free cantilever bridge in Lap Vo has been shown as two independent structures because of the skew crossing over the river.

The cross section of the deck shown in the FS is two single cell concrete box girders. The spans of the bridge are 47+72+47 meters. The total width of the deck is 26.1 m. In this bridge limited structural depth is required in order to keep the road level as low as possible. Super-T approach spans are used in the approach bridges. The superstructure has two separate bridge deck slabs with a joint in the deck slabs between the two structures.

**2.5.3 Cross section of the Superstructures**

**2.5.3.1 Super T40 girder**

The width of the deck varies in the bridges. In the project there is four different total widths in the superstructures: 2x10.5 m, 20.6 m, 26.1 m (for Lap Vo bridge) and 24.5m (for approaches of Cao Lanh bridge). The girders are 1750 mm deep. The minimum thickness of deck slab on Super-T surfaces is 175mm.

- For the bridges of 2x10.5 m wide, each span comprises five (5) precast, pre-tensioned Super-T girders, spaced at approximately 2.1 m centres.

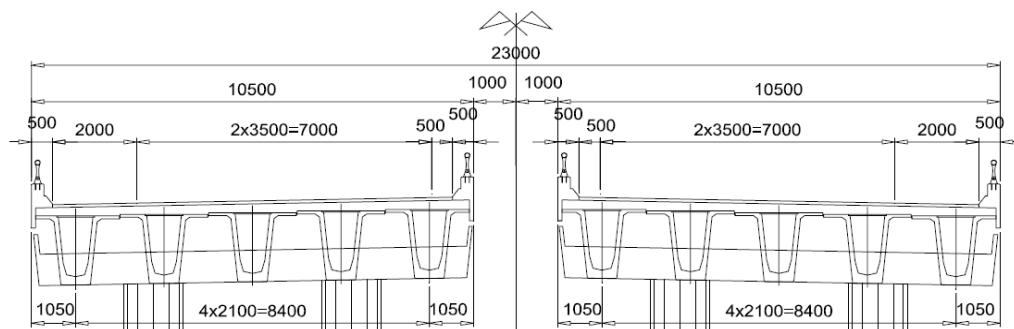

- For the bridges of 20.6 m wide, each span comprises ten (10) precast, pre-tensioned Super-T girders, spaced at approximately 2.03 m centres.

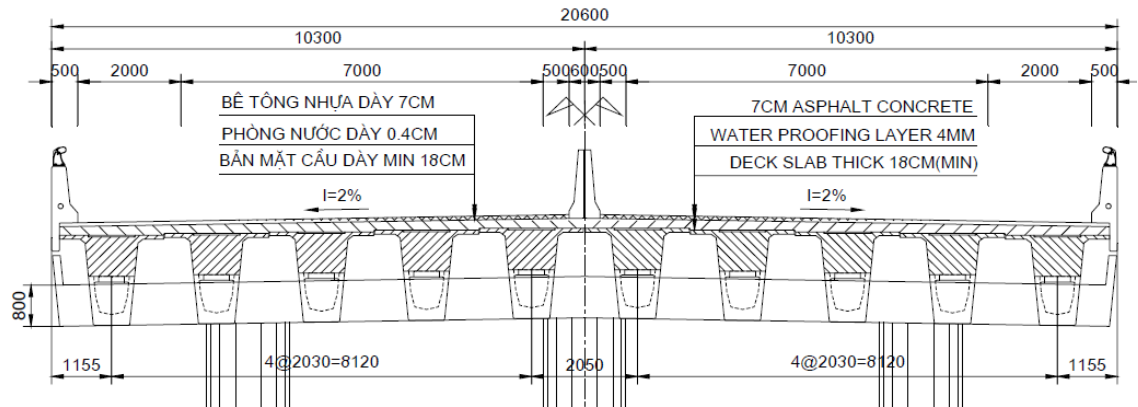

- For Lap Vo bridge, each span comprises twelve (12) precast, pre-tensioned Super-Tee girders, spaced at approximately 2.13 m centres.

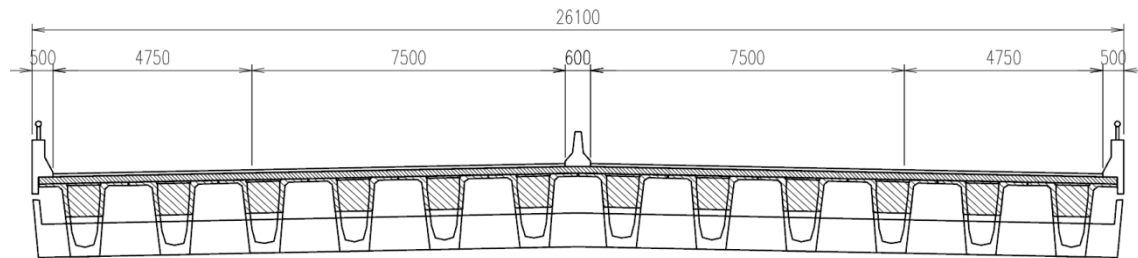

- For approaches of Cao Lanh bridge, each span comprises eleven (11) precast, pre-tensioned Super-T girders, spaced at approximately 2.24 m centres.

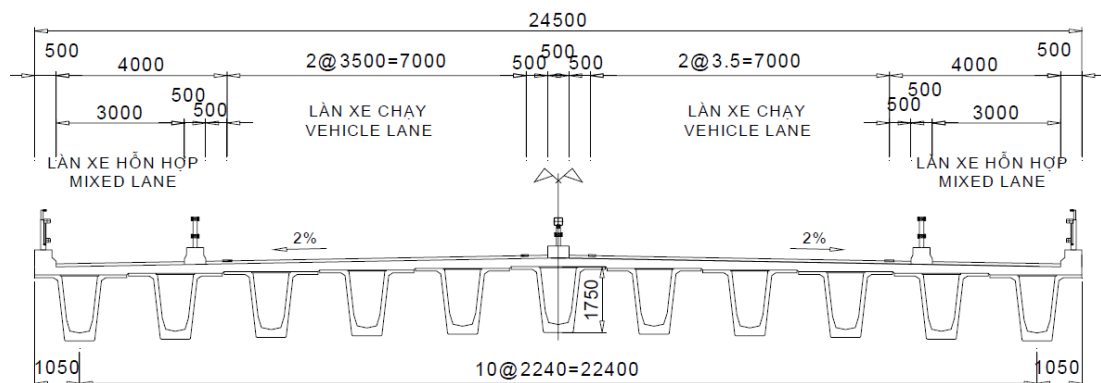

Transverse diaphragm between the girders at the end of girders provides torsional restraints for the girders. These diaphragm beams also provide a jacking point to raise the superstructure for bearing replacement if necessary.

### 2.5.3.2 I-girder

The width of the deck is 20.6 m, each span comprises 9 (nine) I girders, spaced at approximately 2.40 m centres. The girders are 1650 mm deep.

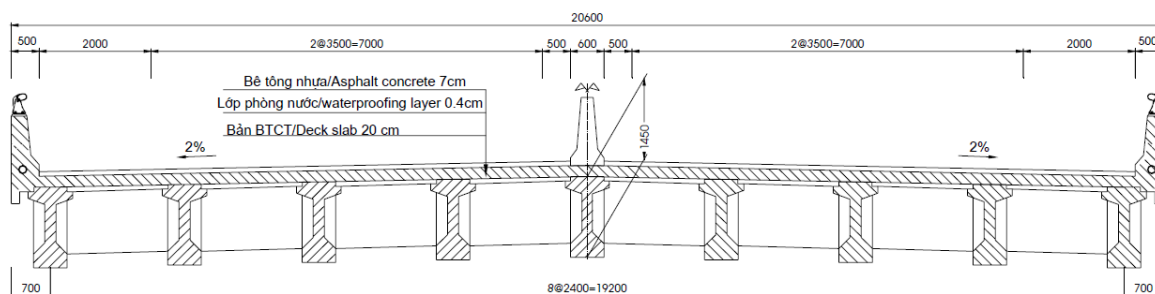

### 2.5.3.3 Voided Slab

There are three different total widths in the superstructures: 2x10.5m, 2.6 m and 23.0m.

- For the bridges of 2x10.5 m wide, each span comprises ten (10) precast, pre-tensioned Voided slab, spaced at approximately 1.0 m centres

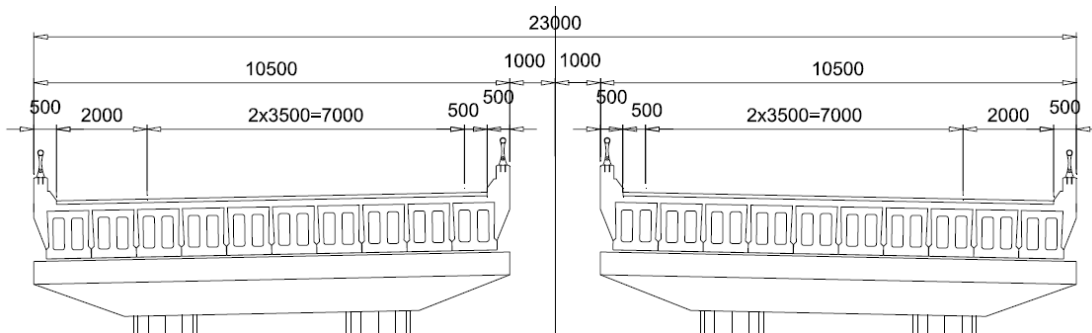

- For the bridges of 20.6m wide, each span comprises twenty (20) precast, pre-tensioned Voided slab, spaced at approximately 1.0 m centres

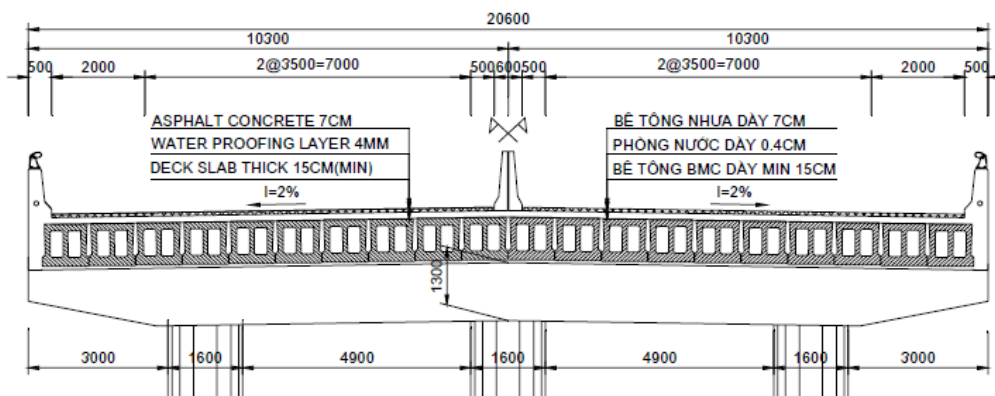



- For the bridges of 23,0m wide, each span comprises twenty three (23) precast, pre-tensioned Voided slab, spaced at approximately 1,0 m centres

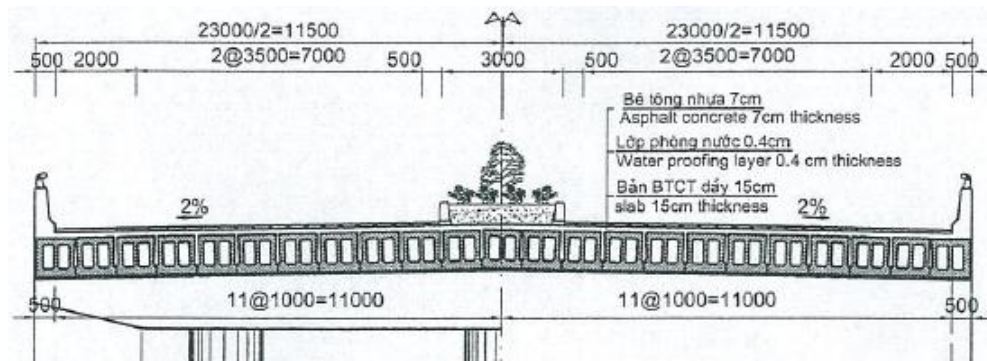

**2.5.4 Bridge Abutments**

Abutments comprise reinforced concrete structures supported on bored piles either 1000 mm or 1500 mm diameter or driven piles 450 mm x 450 mm.

The abutments will be designed to carry vertical and lateral loadings.

At each bridge abutment, the approach slab will be fixed to the bridge to prevent settlement of the road surface directly adjacent to the bridge. The backfill and compacting of the earth behind the abutment will be done before girder erection.

The abutment structures in the project will use the same structural type.

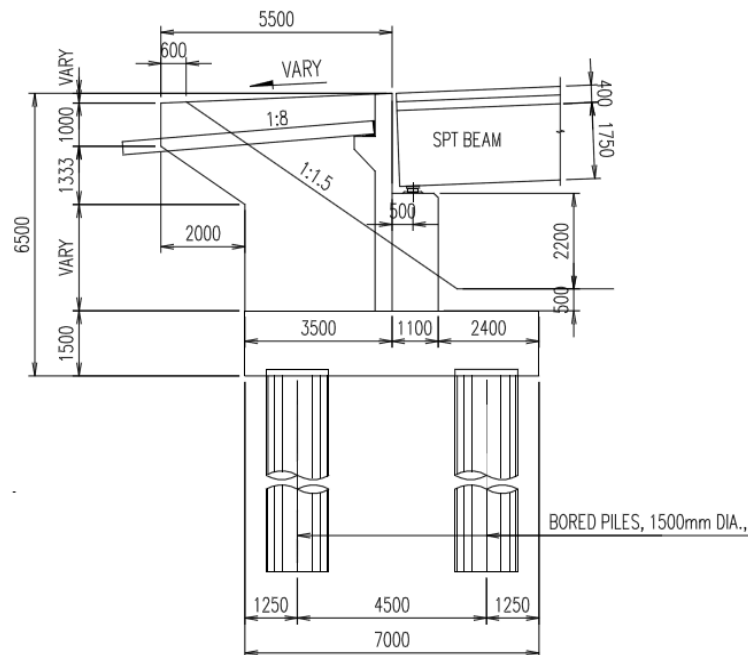

**Type of abutment structures in the project –Bored piles**

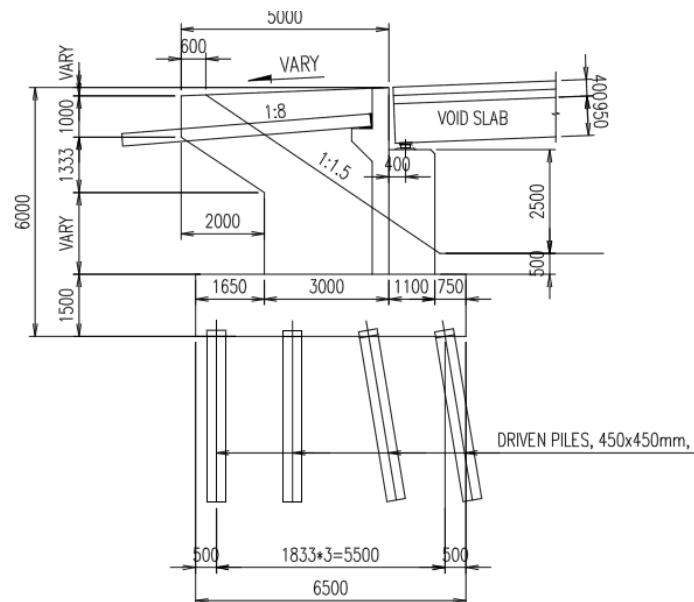

**Type of abutment structures in the project –Driven piles**

### 2.5.5 Bridge Piers

For the piers for the bridges with the deck width of 2x10.5 m, the superstructure will be supported by a pair of circle columns 1400 mm diameter with a crosshead beam of reinforced concrete.

For the piers for the bridges with the deck width of 20.6 m, the superstructure is supported on three circular columns 1600mm diameter with a crosshead beam of reinforced concrete.

For Lap Vo Bridge, the piers supporting the main bridge deck have two single columns. At each approach bridge pier, the superstructure is supported on a pair of oval columns with a crosshead beam of reinforced concrete.

For approaches of Cao Lanh bridges, at each approach bridge pier, the superstructure is supported on a pair of shaped columns with a crosshead beam of reinforced concrete.

### 2.5.6 Bridge Foundation

Most of the ground on the highway route is formed of a very soft clay layer of high void ratio, high compressibility and low shear strength. Such ground of soft clay will cause problems of settlement, stability and lateral movements. As the bearing stratum in most areas exists at a very deep level under the ground, the bridge foundation requires long piles and, thus, high cost. Cast-In-Situ Concrete piles result in a minimum number of piles with the maximum cross section area and can penetrate deep enough will be used for the bridge foundations. Driven piles will give cost savings in the construction works. Some of the bridges may use driven pile foundation at abutments and at intermediate piers if the settlement can be kept to acceptable limits.

The FS proposes to use reinforced concrete driven pile foundations of 450 mm x 450 mm and bored pile foundations of diameter 1.0 m or 1.50 m.

### 2.5.7 Bearings

The technical specification for the Bearings is as specified in the AASHTO LFRD Bridge Construction Specifications, 2004.

Prefabricated element bridges use elastomeric bearings at supports. In Super-T bridges with several spans linked together the longitudinal movements may cause pot bearings to be used as well. The Cao Lanh approach bridge bearing system needs to be studied carefully. In elastomeric bearings later jacking operation may be useful to mitigate the shear stresses caused by long term effects.

### **2.5.8 Expansion Joints**

Expansion joint numbers in each bridge depend on the bridge and movement range.

The deck slabs of approach spans in the Cao Lanh Bridge are to be designed continuous using link slab system between expansion joints. Expansion joints are needed at abutments and intermediate piers and between the cable-stayed bridge and approach bridges. Two additional intermediate expansion joints are needed on each side of the main bridge.

In Lap Vo bridge four expansion joints are needed located at abutments and at intermediate piers between the free cantilever bridge and the approach bridges.

In other bridges, the expansion joints are located on each support.

### **2.5.9 Bridge Drainage**

Drainage from the main bridge spans and sections of the approach bridge that are over water or tidal areas will be through scuppers to the river below, subject to environmental constraints.

Drainage from the approach bridge spans that are over roads and landscaped or environmentally sensitive areas will be collected in pipes under each side of the deck. From the collection pipes, water will be taken by down pipes, located at every pier, to a “soak-away” or the local drainage network.

The scupper spacing will be determined in the detail design phase.

### **2.5.10 Bridge Barriers**

The median barrier and traffic barriers conform to international regulations. Barriers such as the New Jersey type concrete barriers shall be used.

A high traffic barrier is used on both side of the bridge consisting of a truncated New Jersey type concrete barrier with a steel, twin rail barrier mounted on top.

### **2.5.11 Underpass Culverts**

Underpass culverts are concrete box frame structures founded on driven piles. Five underpass culverts form an abutment structure to the small span bridge. Two culverts have been designed for light traffic. Suitable approach slabs are recommended to alleviate the problem of settlement of the adjacent road.

### **2.5.12 Comments and alternative proposals for FS design bridges**

#### **2.5.12.1 Tan My Flyover**

The FS-design is a solution with nine spans of Super-T 40 m spans. The general plan of the design does not show the ramp, which will widen the bridge deck. A special design to accommodate the widening the deck is needed.

**2.5.12.2 Kenh Xang Muc Bridge**

The FS-design is a solution with 7 spans of Super-T 40 m spans. The bridge intermediate support lines are located in skew angle of 68 degrees to the bridge line. This solution requires new formworks for skew ends in the girder. The girder end reinforcing is very dense and the structure is also sensitive to cracking. The skew may cause problems.

The bridge plan appears to allow changing this bridge to have piers that are square to the deck. This will require changes to the pier and crosshead.

The Consultant will propose formally to make these technical changes

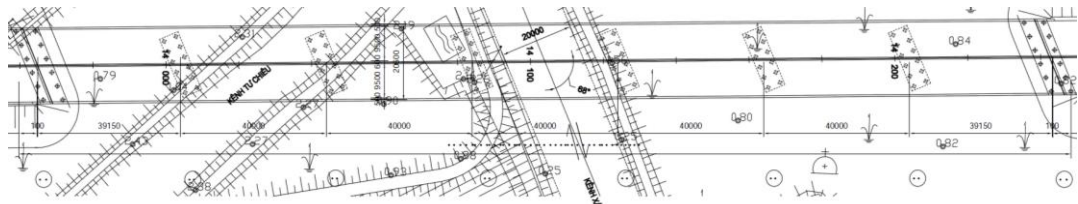

**FS Plan View**

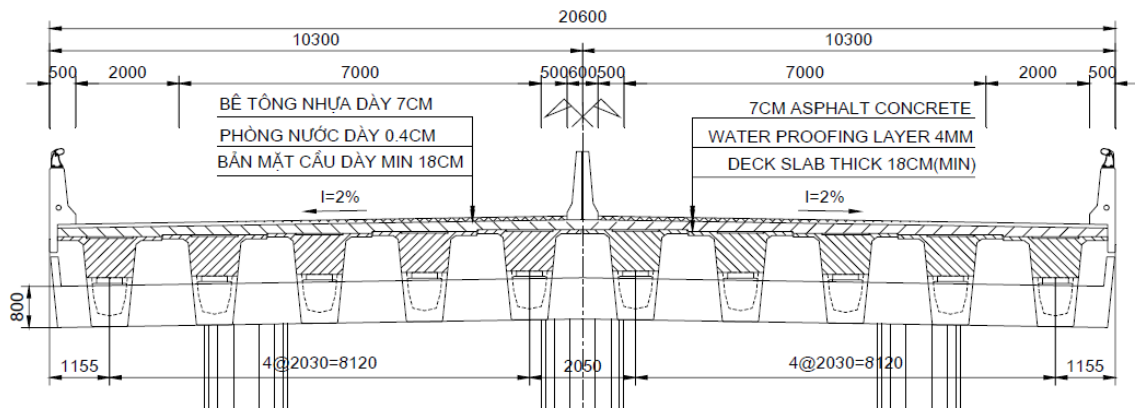

**FS Cross Section**

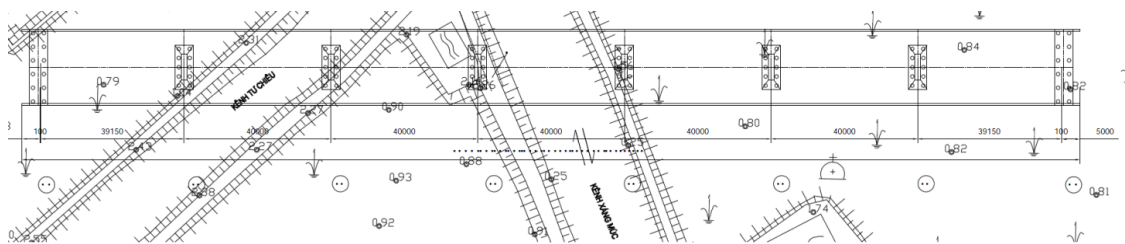

**Proposed Plan View**

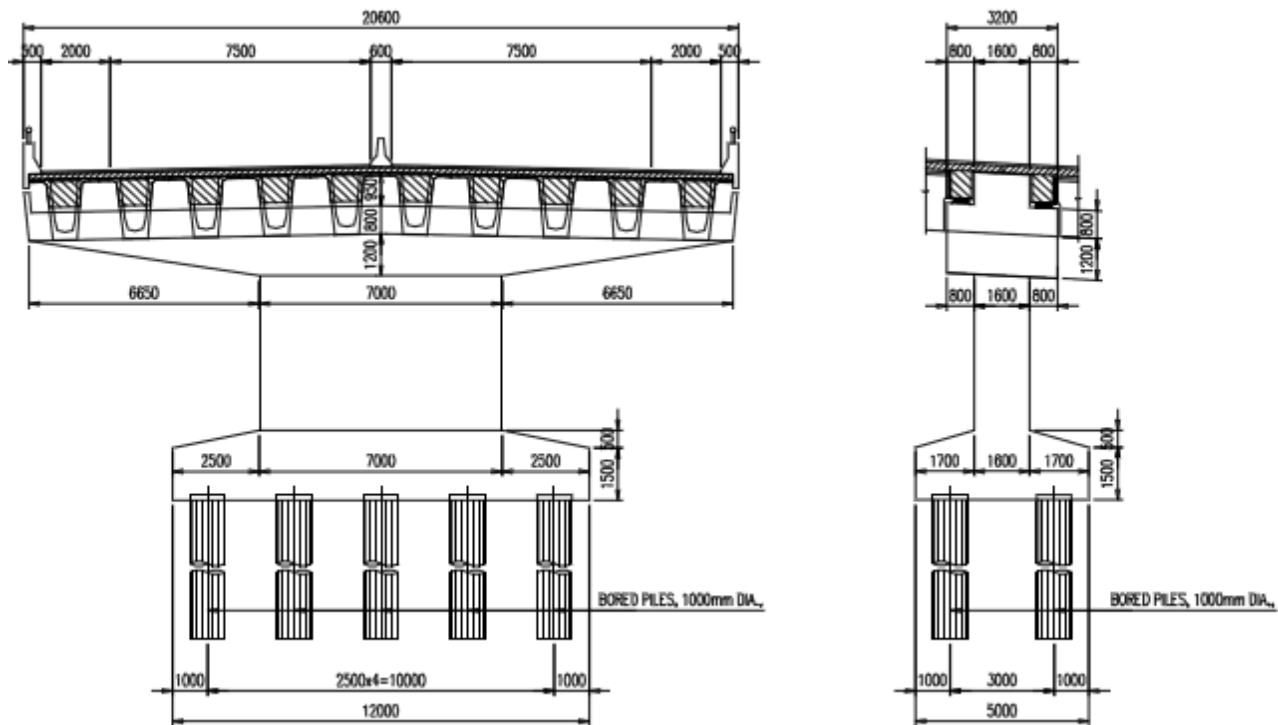

**Proposed Pier and Stock Head**

*Comparison table*

Item	FS Design	Proposed Design
Super-T formworks	Changes to formwork needed	No changes needed
Super-T safety and quality	Difficult, dense reinforcing	Standard reinforcing
Abutments and piers	Formwork skew	Standard System
Appearance of the bridge	Standard Appearance	Crosshead Visible
Costs	Higher costs	No additional costs

### 2.5.12.3 Lap Vo Bridge

FS-design includes special span arrangement because of the skew crossing over the river. The three middle spans over the river comprise of free cantilever bridges using spans 47.0m + 72.0m + 47.0 m.

The approach spans are Super-T40 solutions with spans of 40 m and 30 m. The free cantilever bridges have been suggested in the FS to be built as two single bridge units because of the skew at intermediate support locations.

The vessel traffic in the river is heavy.

The free cantilever bridge could be designed with perpendicular supports and as single unit with spans 42.0 m + 72.0 m +42.0 m. The proposal is to change the cross section girder and use a transversely post-tensioned deck slab. This solution makes it possible that all the approach

bridge spans girders have equal length girders and square ends. The total bridge length is kept the same as the FS-study.

Consultant proposes to make these technical changes to the bridge.

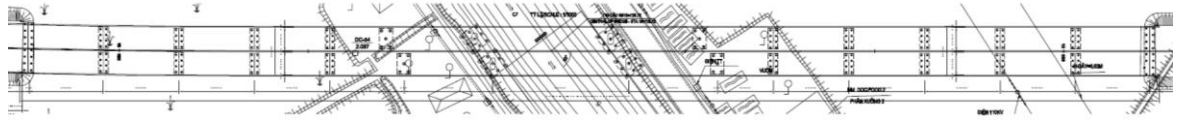

**FS Plan View**

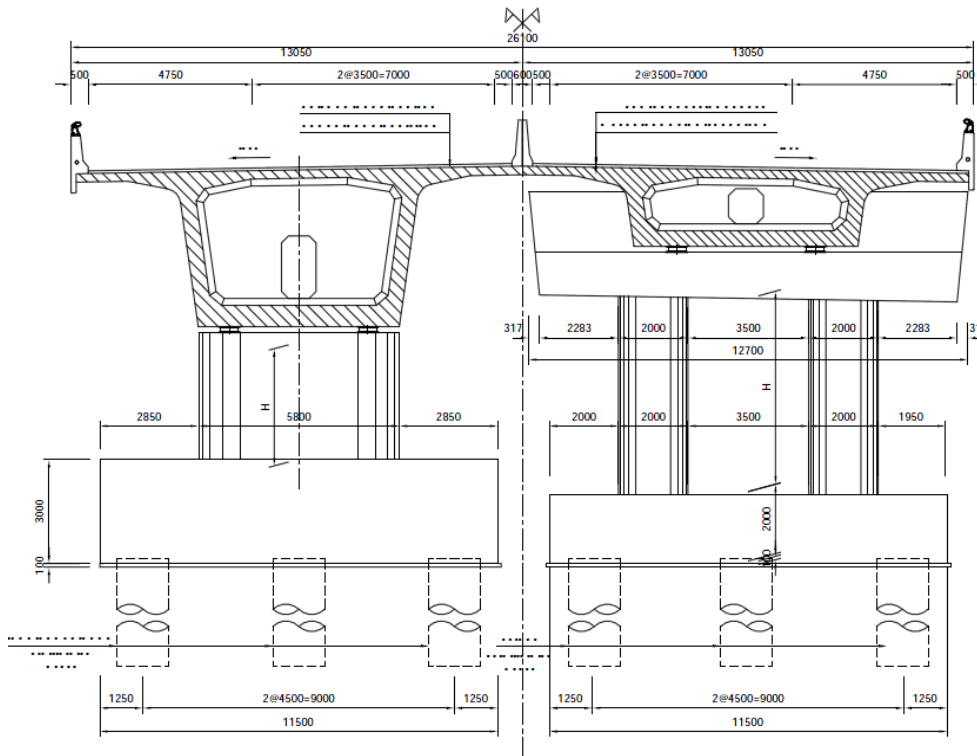

**FS Cross Section**

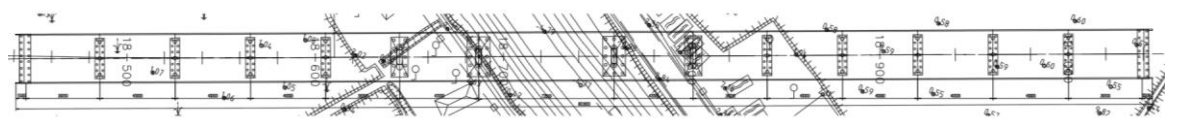

**Proposed Plan View**



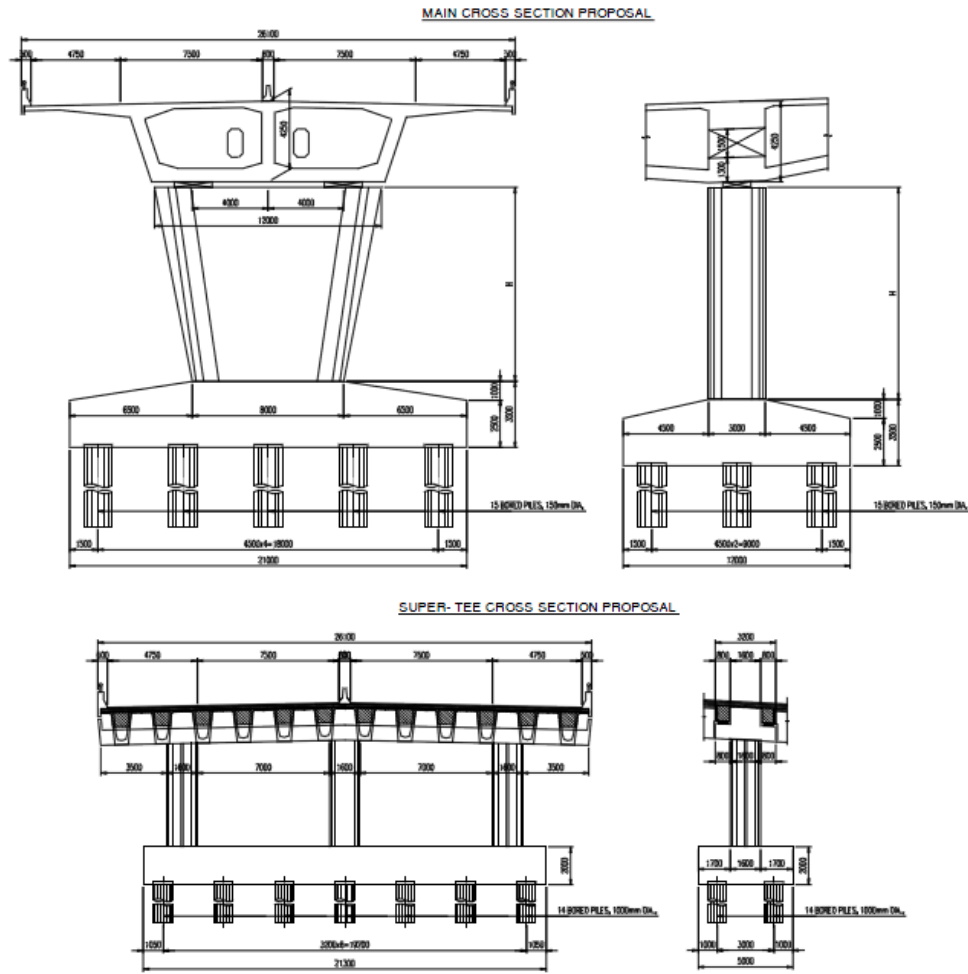

**Proposed Cross Sections**

*Comparison table*

Item	FS design	Proposed design
Super-T formwork,	Varying spans lengths	Only 40 m spans
Free cantilever stages	Two separate bridges	Only one bridges
Construction time, costs	Longer time, additional costs	Shorter time, cost savings

**2.5.12.4 Linh Son Bridge**

The study of Linh Son Bridge has indicated that the slope stability at the other abutment area is weak. It is proposed to move the bridge by 5 m to the direction of Sa Dec.

**2.5.12.5 For S21, S24 and I type Bridges**

**For superstructure:**

- The spacing of the I-girders should be changed from 2.5m ~ 2.8m to 2.35m (the number of girders will increase from 8 to 9).

- Use only one type of voided slab 24m, with height is 0.95m and 21m with 0.8m height

**For Substructures:**

- The shape of pile cap should be arranged along the direction of the bridge.
- Change the number of pier columns , from double column to single column, from treble column to double column (see Table 1 and 2 below).

**Table 1**

No.	Alternatives	Discription	Evaluation Criteria						Diagram	Proposal
			(1) Construction for pilecap	(2) Construction time	(3) Effects of creep, shrinkage, settlement to structures	(4) Ability of clearance under the bridge	(5) Quantity (Concrete) H=5m	(6) Aesthetics		
1.		Double column Mark 7 Explain - Quantity construction for pilecap is more	6 - Longer construction time	6 - More effective	7 - Less clearance	7 - More material.	9 - Beautiful	95.64 m3	1. Double column 	
2.		Single column Mark 9 Explain - Quantity construction for pilecap is less	9 - Faster construction time	9 - Less effective	9 - More clearance	9 - Less material.	9 - Beautiful	92.27 m3	2. Single column 	Selected
3.		Single column Mark 9 Explain - Quantity construction for pilecap is less	7 - Faster construction time	9 - Less effective	8 - More clearance	9 - Less material.	9 - Beautiful	92.18 m3	3. Single column 	

**Table 2**

No.	Alternatives	Discription	Evaluation Criteria						Diagram	Proposal
			(1) Construction for pilecap	(2) Construction time	(3) Effects of creep, shrinkage, settlement to structures	(4) Ability of clearance under the bridge	(5) Quantity (Concrete) H=5m	(6) Aesthetics		
1.		Treble column Mark 7 Explain - Quantity construction for pilecap is more	7 - Longer construction time	7 - More effective	7 - Less clearance	7 - More material.	9 - Beautiful	250.12 m3	1. Treble column 	
2.		Double column Mark 8 Explain - Quantity construction for pilecap is less	8 - Faster construction time	8 - Less effective	8 - More clearance	8 - Less material.	8 - Beautiful	248.49 m3	2. Double column 	Selected

**2.5.12.6 Adjusting skew angles**

It is proposed to adjust the skew angles to use same the same angles. This proposal keeps the needed clearances under the bridge unchanged, but reduces the costs of the bridges. This proposal concerns in total seven bridges listed in the summary index table.

**2.5.12.7 Comments on pile lengths**

A study of the FS design indicates that some of bridges will need longer plies than shown in the FS design drawings. The bridges are listed in the summary index table, below.

### 2.5.12.8 Barrier type

It is proposed to use same traffic barriers and median barriers in all bridges.

### 2.5.13 Summary table of Comments and alternative proposals

The table below will summary the comments and alternative proposals for superstructure.

Package	Bridge Name	General drawing			Span		Skew (°)	
		Station	Length (m)	Proposal position	Arrangement	Proposal	in FS	Proposal
Cao Lanh bridge	Dinh Chung	Km 0+330	368.4		9xT40		90	
	Linh Son	Km 1+130	130.3	Remove bridge to A2: 5m	5xS24		70	
	Khem Ban	Km 1+510	34.1		1xS24		48° 16'	50
	Tinh Thoi (L)	Km 2+420	464.4		5T40+28+T40+28+4T40		90	
	Tinh Thoi (R)		448.4		11xT40		90	
	Rach Mieu	Km 3+748	34.1		1xS24		90	
	Tan My	Km 7+300	368.4	General plan does not show the ramp	9xT40	A special design for widening the deck is need	90	
Component 2: Cao Lanh-Vam Cong section	Ditch_Km 8+033.27	Km 8+033.27	82.2		3xS24		55	
	Thay Lam	Km 8+620	139.3		2S24+I33+2S24		80	
	Muong Lon	Km 10+199	274.6		11xS24		70	
	Dat Set	Km 11+460	235.5		4S24+I33+4S24		55	
	Ditch_Km 13+293.37	Km 13+293	43.1		I33		45	
	Xang Muc	Km 14+104	290.2		7xT40		68	90
	Ditch_Km 15+268.54	Km 15+268.54	31.1		1xS21		46	45
	Tan Binh	Km 15+827	307.5		9xI33		75	
	Ditch_Km 16+394.28	Km 16+394.28	73.2		3xS21		56	
	Xang Nho	Km 16+921.48	73.2		3xS21		60	56
	Ditch 2-9	Km 17+325.16	241.4		7xI33		45	
	Rach Vuot	Km 17+760	73.2		3xS21		45	
	Song Lap Vo	Km 18+748.75	603.4	Cantilever bridge could be designed a perpendicular single unit	5T40+(47+72+47)+29.5+5T40	5T40+(42+72+42)+6T40	90	
	Rach Lap vo	Km 19+730.95	41.6		1xS24		70	
Kenh Rach	Km 21+435	41.6		1xS24		57	55	
Ong Hanh	Km 22+036	34.85		1xS21		67		
Xep Cut	Km 23+248	61.9		2xS24		83	85	
Component 3: Vam Cong bridge	Channel 1	Km 27+090	35.1		1xS24		84	85
	Channel 2	Km 27+510	35.1		1xS24		87	85
	Channel Nga Chua	Km 28+140	62.4		2xS24		85	

The dimensions and details of substructures will depend on data obtained during the geotechnical investigation works during the detailed design period. If there are major differences between the designs shown in the FS and those resulting from the design based on the geotechnical survey, the Consultant will submit their study to the Client for approval.

## 2.6 Cao Lanh Cable Stayed Bridge

### 2.6.1 General

The basic design parameters for the design of Cao Lanh Cable-Stayed Bridge will be reviewed in this section.

We concur with the recommendation of the Feasibility Study Report that a cable-stayed bridge is a reasonable solution for this region, and alternative proposals for the component of the cable-stayed bridge will be shown for the further optimization in the detailed design stage.

## 2.6.2 Natural conditions and site environment

### 2.6.2.1 Natural conditions

Natural conditions will become a basis for the bridge detailed design. These values for temperature, humidity, rain and wind were proposed and reviewed in the Feasibility Study. However data collection and survey near the bridge sites will be carried out in the detailed design stage and analyzed for adoption as design values. Before the final values are adopted, these values could be used temporarily.

#### *Temperature*

The range of temperature shall be considered in accordance with 22 TCN 272-05 Clause 3.12.2

#### *Humidity*

Humidity data is used for design for creep and shrinkage effects on concrete structures of the bridge. Average relative humidity is 82% and this is considered appropriate for use in detailed design.

#### *Rainfall*

Rain intensity data is used in drainage design to determine drain pipe diameter and spacing. The rainfall intensity of 140mm/hr is applied to design drainage utilities.

#### *Wind*

According to the Vietnamese Specification for Bridge Design (22 TCN272-05), a 3-second wind gust specified for the Wind Zone I in which this region is located, is 38m/sec. With a correction factor of 1.09 for open terrain to be applied for these areas and a 0.756 conversion factor for 10-minutes average wind speed from 3-second gust wind, the basic wind speed  $V_{10}$  becomes 32m/sec. The cable-stayed bridge shall be designed for the wind design speed of 32m/sec of basic wind speed. If the wind design basic speed after data survey is shown to be greater than 32m/sec, the higher value will be adopted for design.

#### *Earthquake*

According to the Vietnamese Specification for Bridge Design (22 TCN272-05), the site is included in seismic zone 2 which has 0.09~0.19 for the acceleration coefficient. The importance category will be critical, soil condition with soft to medium dense clayey deposits to be applicable to this region is classified as type III and its corresponding site coefficient is 1.5.

#### *Water Level*

The highest and lowest water levels are defined for design based on a 100-year return period. The maximum water level as a basis for navigation vertical clearance is usually based on a 20-year return period.

#### *Water Flow Speed*

The maximum water flow speed is used to calculate water stream pressure acting on foundations as well as to estimate the scour depth around the foundation. Average water flow speed is used for estimating local scour due to annual discharge and this effect is combined with other loads.

**2.6.2.2 Site Environment**

*Navigational Consideration*

Navigational clearance of the Tien River under the Cao Lanh Bridge is a complicated issue depending on technical requirements of vessels and international relations.

Agreements among the neighbouring nations confirm that: waterway transport in the Mekong River is subject to freedom and countries who sign these agreements should not cause obstacles to the movement of vessels. My Thuan Bridge and Rach Mieu Bridge are located on the downstream side of Cao Lanh Bridge and allow 5,000DWT vessels to pass in both directions at the same time (2 ship lanes) or a 10,000DWT vessels to pass in one direction (1 ship lane).

- According to plan of the Mekong River Commission, the river from Cua Tieu to Cambodia will be improved to serve 5,000DWT vessels.
- At present, Cao Lanh and Phnom Penh ports can serve only 2,000-3,000DWT vessels.
- Expansion projects in the future will only allow 5,000DWT vessels.
- From Phnom Penh to the sea, either the Hau River or Tien River can be used. In addition Kampong Chang port lies in the Gulf of Thailand, 230km from Phnom Penh and can serve 10,000 - 12,000DWT vessels.

Based on the above analysis, it is recommended that the navigational clearance of Cao Lanh Bridge should be equal to that of My Thuan Bridge and Rach Mieu Bridge to ensure:

- Operation of 5,000 DWT vessels (h=30m) to pass with a channel width of 200-220m;
- Operation of 10,000 DWT (h=37.5m) to pass in one direction with the width of 110m

However, according to international agreements, it is necessary that Cambodia be informed via the Mekong River Commission.

Names of Bridge	Name of River	Width of River (m)	Navigation Clearance		Skew of Bridge
			Width (m)	Height (m)	
Cao Lanh	Tien River	About 800 m	220 m	30.0 m	0°
			110m	37.5m	

*Topography and Geotechnical Data*

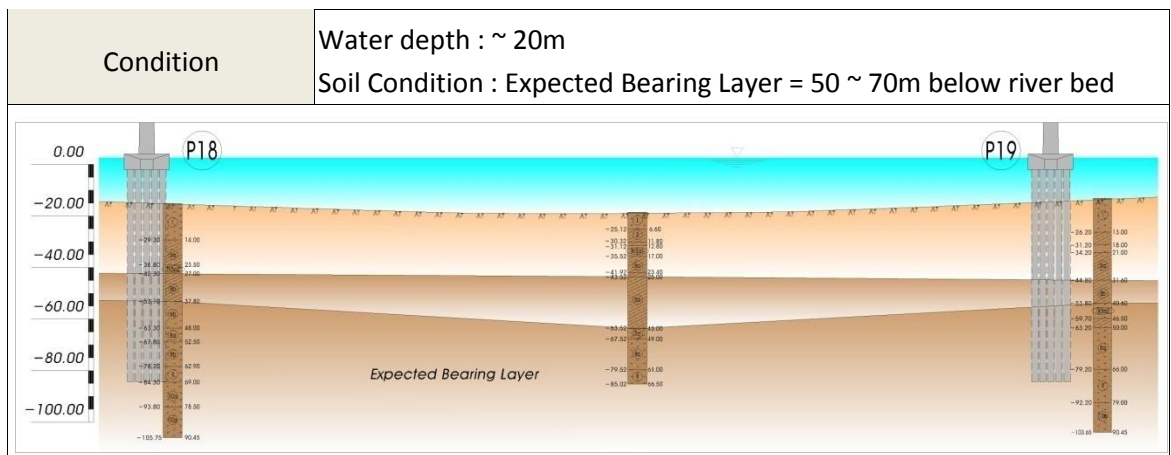

In the detailed design stage, boreholes should be carried out at the exact location of supports and abutments. The drilling depth should be increased at any location where no bearing layer is clearly defined.

### 2.6.3 Basic Concept of the Cable-Stayed Bridge

Cao Lanh Cable-Stayed Bridge is the main bridge of this project. Vietnam has successfully built many cable-stayed bridges starting with the My Thuan Bridge. One of the latest examples is Phu My cable-stayed bridge in Ho Chi Minh City. The construction of this bridge demonstrates the feasibility of a similar structure for the Cao Lanh Bridge. The span arrangement and basic dimensions of the bridge can be summarized as:

- Cao Lanh Bridge will be a cable-stayed bridge with approach viaducts.
- The Cao Lanh cable-stayed bridge will have a central span of 350 m and the back-stay spans of 150 m. The bridge requires a navigation clearance of  $H_{max}= 37.5$  m and  $B_{max}= 220$  m.
- The total length of the bridge, including the approach viaducts, will be 2,010 m – with spans of  $17 \times 40 + (150+350+150) + 17 \times 40$  (m).
- The cable-stayed bridge will have H-shape towers and a slender cast in situ concrete girder superstructure with a double-plane of cables in a semi-fan type configuration.
- The approach bridges will use Super-T girders as the deck structure.
- The bridge will be founded on large diameter cast-in-situ concrete piles. Pile caps and piers will be cast-in-situ concrete structures.

The Cao Lanh Cable-Stayed Bridge will be 650 meters in total length with the main span being 350 meters and will be 120 meters high and 24.5 meters wide. Approaches to this bridge from both directions will be 680 meters in length on a viaduct with a grade that will enable bridge users, especially heavy container trucks, to cross the bridge effortlessly.

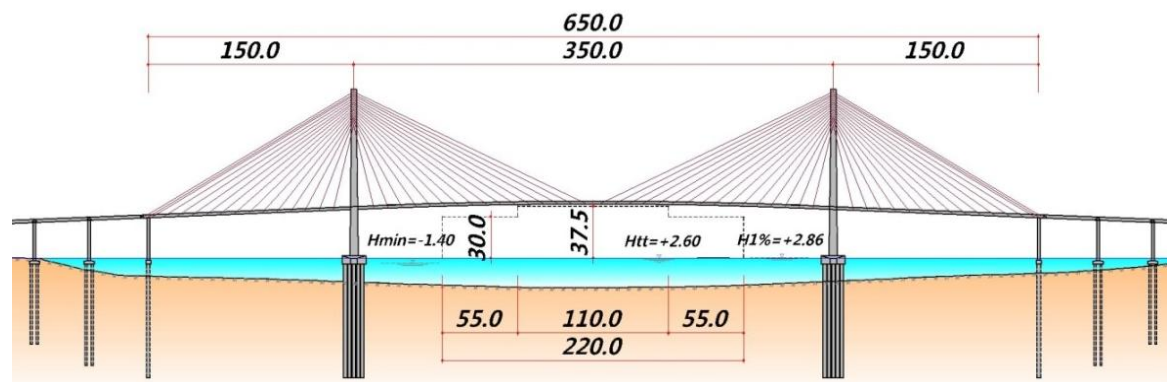

#### Cross Section

A concrete girder is recommended since this is likely more economical than a steel composite girder and similar types have already been constructed in Vietnam. The 27.5m wide deck consists of two edge girders connected by cross beams, the cross beams being spaced at 5.2m. The stay cables connect to the outside edges of the deck.



The concrete girder has advantage of easy construction with low construction cost and improved maintainability. This form of girder has been constructed on the My Thuan and Phu My bridges.

GENERAL

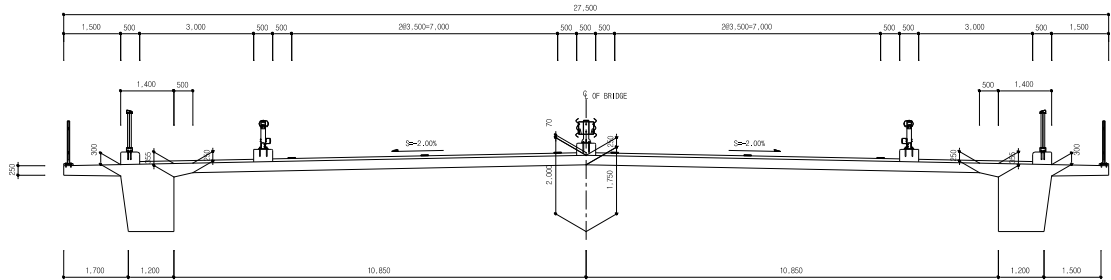

AT CABLE ANCHORAGE

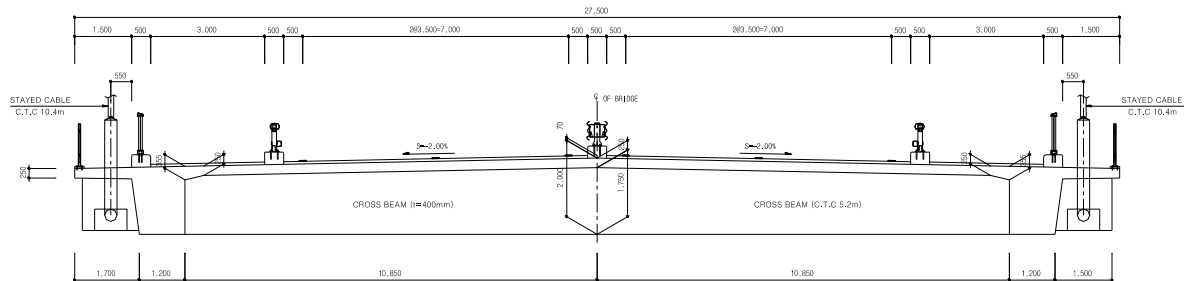

AT CROSS BEAM

*Cable System*

The cable-stayed bridge will utilize the semi-fan cable arrangement with two cable planes attached along the edges of the deck. This is an efficient structural arrangement, as the cable system will offer efficient support both vertically and torsionally to the deck.

*Pylon*

The H-shaped concrete towers, have high stiffness in the transverse direction and, due to the member shape, high resistance against buckling. It also has advantage of providing a sense of continuity and unity by having identical materials for the tower and piers.

However, it will be necessary to utilize heavy temporary trusses to support both the formwork and the wet concrete during construction.

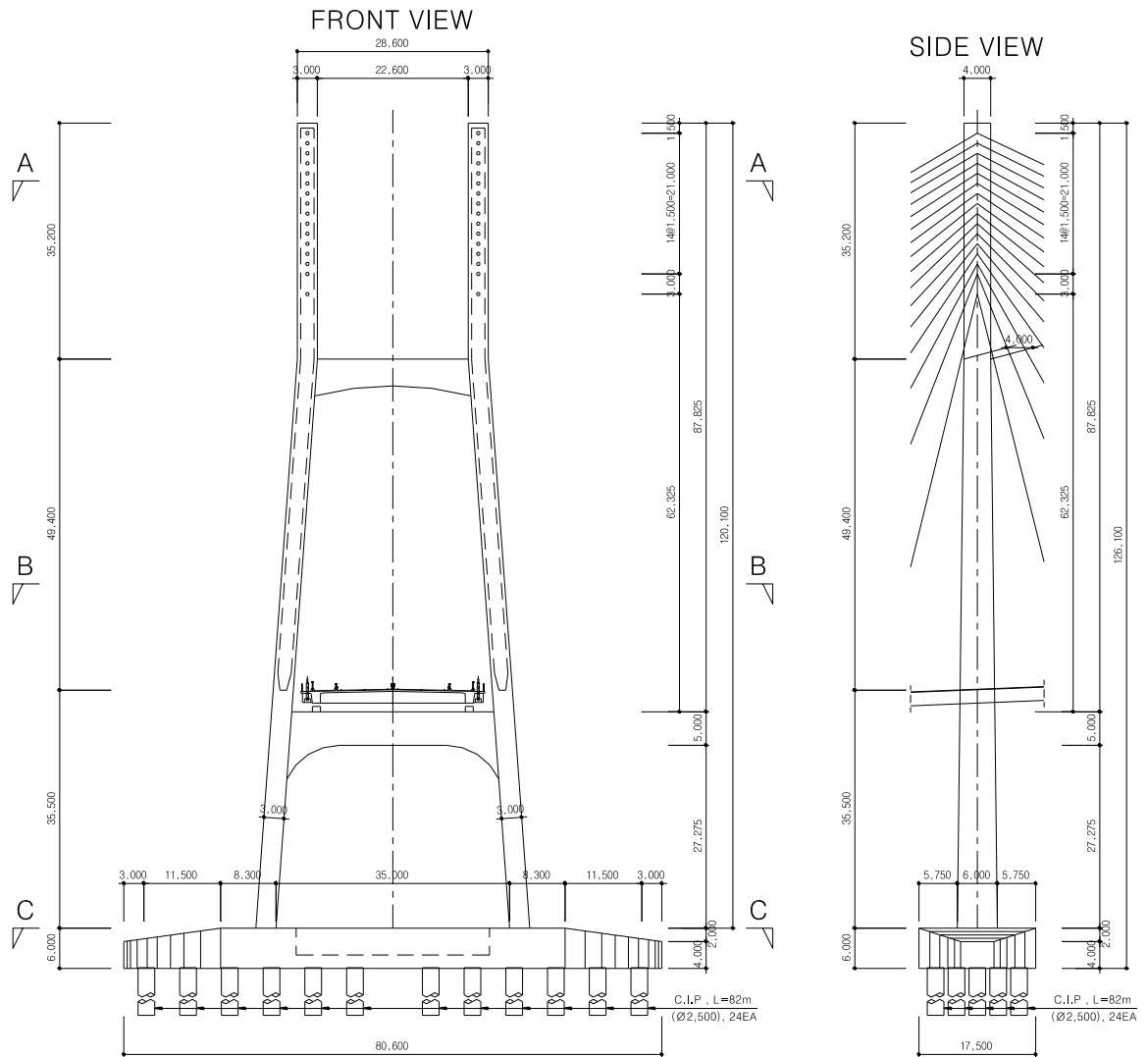

### 2.6.4 Basic Design Concepts

#### Safety

The provisions of the adequate design standards for long span bridge are considered to yield reliable, durable and serviceable structures.

The primary responsibility shall be providing safety for the traffic on the bridge and vessels under the bridge. Safety against seismic events, wind forces and possible ship collision will be considered in accordance with the latest international requirements.

#### Serviceability

<b>Durability</b>	<p>The design service life of the Cao Lanh bridge shall be 100 years. The structural concept and composition of the construction materials used in the project should have a sufficient durability required for each component part and their details to provide protection against all environmental effects.</p> <p>A 100 year service life is required for the main structures:</p> <p style="text-align: center;">Girder, pylons, anchor piers, piers, piles, and abutments.</p>
-------------------	--

	<p>A shorter design life is acceptable for the:</p> <p style="padding-left: 40px;">Stay cables, bearing, secondary fixed structures (barriers, railings, fairings, etc.), movable/mechanical elements (expansion joint, inspection gantry, elevator), electrical system (power supply and lighting system) and wearing surface.</p>
<p><b>Inspectability</b></p>	<p>The design shall be prepared so that the required inspection and maintenance of the structure will be kept at a minimum. Facilities for easy access to vital details, e.g. joints and cable anchorages, shall be provided.</p>
<p><b>Maintainability</b></p>	<p>Minimum operational and maintenance requirements and costs shall be an objective, including replaceability and inspectability of critical items with a shorter design life than 100 years.</p>
<p><b>Deformations</b></p>	<p><i>Criteria for Deflection</i></p> <p>Deflection of the main span under live load shall not encroach on navigation clearance (load combination SERVICE LIMIT I-1). Verification of sufficient clearance shall be made.</p> <p><i>Criteria for Dynamic Deflection</i></p> <p>Noticeable wind induced oscillations/vibrations may not occur. Cable, pylon and girder oscillations shall be assessed.</p> <p>The maximum allowable vertical harmonic acceleration level for single oscillation frequencies at the roadway at girder level is</p> <ul style="list-style-type: none"> <li>- vertical acceleration <math>&lt; 0.5 \text{ m/sec}^2</math> for wind speed <math>V \leq 25 \text{ m/sec}</math></li> </ul> <p style="text-align: right;">at single frequencies <math>\leq 1 \text{ Hz}</math></p> <p>The maximum allowable vertical harmonic oscillation amplitudes of the roadway due to vortex shedding excitation at girder level shall not exceed</p> <ul style="list-style-type: none"> <li>- vertical amplitude <math>&lt; 0.1 \text{ m}</math> for wind speed <math>V \leq 25 \text{ m/sec}</math></li> </ul> <p>Oscillation accelerations caused by random buffeting of the bridge girder in the cable-supported span due to wind may not exceed:</p> <ul style="list-style-type: none"> <li>- vertical acceleration <math>&lt; 1.5 \text{ m/sec}^2</math></li> <li>- horizontal acceleration <math>&lt; 0.5 \text{ m/sec}^2</math></li> </ul> <p>for wind speed <math>V \leq 25 \text{ m/sec}</math> for frequencies below 1 Hz</p> <p>The acceleration levels corresponding to the “reduced proficiency” limits stated in ISO-2631-1978/Addendum 2 1982(E) “Guide for the evaluation of human exposure to whole Body Vibration”.</p>

### *Constructability*

Safe and robust construction methods with minimum influence of adverse geotechnical, current and weather conditions and high probability of completion on schedule shall be assumed.

### *Economy*

Structural types, construction systems and materials shall be selected with due consideration of project cost.

### *Bridge Aesthetics*

The bridge should complement its surroundings, be graceful in form, and present an appearance of adequate strength.

## **2.6.5 Design Standards and Criteria**

The structural design of the cable-stayed bridge shall be carried out in accordance with the following standards, guide lines and recommendations:

- Vietnamese Specification for Bridge Design (22TCN 272-05).
- AASHTO LRFD Bridge Design Specifications, 4th Edition, 2007.
- Recommendations for Stay Cable Design, Testing and Installation, 5th Edition, 2007, Post Tensioning Institute (PTI).
- Guide Specification and commentary for Vessel Collision Design of Highway Bridges, 2nd Edition, 2010, AASHTO.
- CEB-FIP Model code, 1990, COMIT EURO-INTERNATIONAL DU BETON.
- Recommendation Design Load on Bridges, Journal of the Structural Division, ASCE, ST7, 1981.

PTI recommendations will be used for consideration of additional load and load combinations for replacement and sudden rupture of stay cables. Ship impact load will be applied in accordance with Guide Specification and commentary for Vessel Collision Design of Highway Bridges.

### **1) Loading**

Any loads and load combinations to be considered in the design process, which are additional to loads and load combinations specified in AASHTO LRFD are specifically listed in this document. These additional loads and load combinations are supplementary to the loading provisions of the AASHTO LRFD Bridge Design Specifications. Localized provisions and parameters are adopted from the Vietnamese Standard.

### *Dead Loads*

The unit weight of material as used for design load purposes shall be assumed as follows:

- |   |                          |
|---|--------------------------|
| • Reinforced, prestressed and post-tensioned concrete | : 25.0 kN/m <sup>3</sup> |
| • Asphaltic concrete                                  | : 22.5 kN/m <sup>3</sup> |
| • Structural Steel                                    | : 78.5 kN/m <sup>3</sup> |
| • Fresh Water   | : 10.0 kN/m <sup>3</sup> |

*Earth Loads*

Earth pressure, earth surcharge, and down drag loads shall be considered in accordance with Vietnamese Standard.

*Vehicular Live Loads*

Vehicular live loading on the roadways of bridges or incidental structures, designated HL-93, shall consist of a combination of the:

- Design truck or design tandem, and
- Design lane load.

*Design truck:*

The weight and spacing of axles and wheels for the design truck shall be as figure 1 of section 2.5.1.

*Design tandem:*

The design tandem shall consist of a pair of 110kN axles spaced 1.2 m apart. The transverse spacing of wheels shall be taken as 1.8 m.

*Design lane load:*

The design lane load shall consist of a load of 9.3 kN/m, uniformly distributed in the longitudinal direction. Transversely, the design lane load shall be assumed to be uniformly distributed over a 3 m width.

*Reduction of vehicular live load:*

It has been the practice for bridges designed for length in excess 200 m that a reduction in the design vehicular live load over the full length could be considered. There are in existence many design specifications for allowing a reduction in the design vehicular live load for long span bridge.

We intend proposing a suitable reduction in the vehicular live load which will be subject to review and confirmation by CUU LONG CIPM . The design code of Honshu-Shikoku Bridge Authority (Japan), San Francisco Oakland Bay Bridge Specifications (USA), and Cable-supported Steel Bridge Design Specification (KOREA) are shown for reference only.

Honshu-Shikoku Bridge Authority		
Loaded Length (m)	Reduction Factor for Lane Load	Reduction Factor for concentrated Load
$0 < L \leq 500$	1.0	1.0 for truck or tandem load
$L > 500$	$0.57 + 300 / (200+L)$	1.0 for truck or tandem load

San Francisco Oakland Bay Bridge			
Loaded Length (m)	Lane Load (kN/m)		Concentrated Load
$0 < L \leq 183$	9.3	100%	100% of truck or tandem load
$183 < L \leq 366$	$11.625 - L/78.71$	75~100%	$(125-L/7.32)1.0$ for truck or tandem load
$L > 366$	6.975	75%	75% of truck or tandem load

Loaded length is not the span length, but the loaded length of live load to induce the maximum member force with considering the influence line.

Cable-supported Steel Bridge Design Specification			
Loaded Length (m)	Lane Load (kN/m)		Concentrated Load
$0 < L \leq 200$	12.7	100%	1.0 for truck or tandem load
$L > 200$	$12.7 \times (0.57 + 300 / (200 + L))$	66~100%	1.0 for truck or tandem load

*Fatigue Loads*

The fatigue load shall be one Design truck, but with a constant spacing of 9 m between the 145 kN axles. The dynamic load allowance shall be applied to the fatigue load.

The frequency of the fatigue load shall be taken as the single-lane average daily truck traffic (ADTTSL).

*Dynamic Load Allowance*

The static effects of the design truck or tandem, other than braking forces, shall be increased by the percentage specified in the table for dynamic load allowance.

**Dynamic Load Allowance, IM**

Component	IM
Deck Joints All Limit States	75%
All Other Components	
• Fatigue and Fracture Limit States	15%
• All Other Limit States	25%

The factor to be applied to the static load shall be taken as:  $(1 + IM/100)$ . The dynamic load allowance shall not be applied to pedestrian loads or to the design lane load. The dynamic load allowance may be reduced for components, other than joints, if justified by sufficient evidence.

When an analysis for dynamic interaction between a bridge and the live load is required, the Owner shall specify and/or approve surface roughness, speed, and dynamic characteristics of the vehicles to be employed for the analysis. Impact shall be derived as a ratio of the extreme dynamic force effect to the corresponding static force effect.

In no case shall the dynamic load allowance used in design be less than 50 percent of the dynamic load allowance specified in above table, except that no reduction shall be allowed for deck joints.

*Braking Force*

Braking force shall be taken as 25 percent of the axle weights of the design truck or tandem per lane placed in all design lanes which are considered to be loaded and which



are carrying traffic headed in the same direction.

These forces shall be assumed to act horizontally at a distance of 1.8 m above the roadway surface in either longitudinal direction to cause extreme force effects. All design lanes shall be simultaneously loaded for bridges likely to become one-directional in the future.

#### *Vehicular Collision Force*

Unless protected as follows, abutments and piers located within a distance of 9 m to the edge of roadway, or within a distance of 15 m to the centerline of a railway track, shall be designed for an equivalent static force of 1,800 kN, which is assumed to act in any direction in a horizontal plane, at a distance of 1.2 m above ground.

In order to qualify for this exemption, such barrier shall be structurally and geometrically capable of surviving the crash test for Test Level 5, as specified in AASTHO LRFD Section 13.

#### *Water Loads*

**Static pressure** : Static pressure of water shall be assumed to act perpendicular to the surface that is retaining the water. Pressure shall be calculated as the product of height of water above the point of consideration, the density of water, and g (the acceleration of gravity).

Buoyancy shall be considered to be an uplift force, taken as the sum of the vertical components of static pressures, as specified in Static pressure, acting on all components below design water level.

**Stream pressure** : The longitudinal and drag force shall be taken as the product of longitudinal stream pressure and the projected surface exposed thereto.

The lateral drag force shall be taken as the product of the lateral stream pressure and the surface exposed thereto.

The consequences of changes in foundation conditions resulting from the design flood for scour shall be considered at Strength and Service limit states. The consequences of changes in foundation conditions due to scour resulting from the check flood for bridge scour shall be considered at the Extreme Event limit state, except as Earthquake, Vehicular Collision and Vessel Collision.

#### *Wind Loads*

Wind load is one of the governing loads for the design of long-span bridges. Static wind effect on girder, cables and pylons is a major transverse force, while the aerodynamics requirements influence the bending/torsional stiffness of girder and often determine girder shape. It shall be determined the static wind load acting on girder, cables and pylon, following Vietnam Standards.

#### *Earthquake Load*

The Vietnamese Standard design earthquake load as described in Section 2.6.2.1 shall be considered.

#### *Uniform Temperature*

The maximum and minimum average bridge temperatures shall be as specified in Table.

The difference between the maximum and minimum average bridge temperature and the base construction temperature assumed in the design shall be used to calculate thermal deformation effects.

**Temperature change**

Climate Zone	Concrete superstructure	Concrete deck on steel girders or box	Steel deck on steel girders or box
North of Latitude 16° N (Hai Van Pass) *	+5°C to +47°C	+1°C to +55°C	-3°C to +63°C
South of Latitude 16° N (Hai Van Pass)	+10°C to +47°C	+6°C to +55°C	+2°C to +63°C

\* Note: For sites north of latitude 16° N and at an elevation above sea level greater than 700m, the minimum temperature in the table shall be reduced by 5°C.

*Temperature Gradient*

The temperature gradient shall follow the Vietnamese Standard.

*Temperature Difference*

It is usual in design of cable-stayed bridge to consider the temperature difference between the structural components. Consideration for stay cables shall be given to wrapping the HDPE pipes with white tape, using light colored or co-extruded HDPE pipes or painting steel pipes a light color to minimize thermal effects. In the detailed design the temperature differences between stay cables and other components shall be taken as 8°C for brightly colored stays and 22°C for black colored stays respectively.

*Differential Shrinkage*

Where appropriate, differential shrinkage strains between concretes of different age and composition, and between concrete and steel, shall be determined in accordance with the provisions of CEB-FIP Code.

*Creep*

Creep strains for concrete shall be in accordance with the provisions of CEB-FIP code. In determining force effects and deformations due to creep, dependence on time and changes in compressive stresses shall be taken into account.

*Settlement*

Force effects due to extreme values of differential settlements among substructures and within individual substructure units shall be considered as follows.

**Differential settlement** : Tower : 50mm ; Anchor Pier: 20mm

**Rotation angle at the pylon base** : 1.8L/Hx10-4rad

**Pylon erection error** : H/2000

Where, H is distance between top and bottom of pylon and L is length of center-span.

Primary and Secondary Force from Post-Tensioning and Cable prestress

The primary prestress and cable prestress are to be applied as permanent loads. The application of post-tensioning forces on a continuous structure produces reactions at the supports and internal forces that are collectively called secondary forces, which shall be considered where applicable. These effects are considered with load factor 1.0 for all load combination.

#### *Friction Forces*

Forces due to friction shall be established on the basis of extreme values of the friction coefficient between the sliding surfaces. Where appropriate, the effect of moisture and possible degradation or contamination of sliding or rotating surfaces upon the friction coefficient shall be considered.

#### *Vessel Collision*

All bridges crossing navigable waterways shall be designed for vessel collision with the substructures and, where appropriate, the substructures shall be:

- Designed to resist vessel collision forces, and/or
- Adequately protected by fenders, dolphins, berms, islands or other sacrificial devices.

The Tower shall be capable of design load of vessel; 5,000DWT.

Collision force is in accordance with article 3.14.5 of 22TCN 271-01.

#### *Construction Live Loads*

For the cable-stayed bridge, construction live load shall be taken into account by rational analysis including the effects of the available construction equipment upon the partly erected bridge. Distributed construction live load or specialized construction equipment load shall be considered.

#### *Cable Replacement Force*

The design of cable-stayed bridge shall provide for the replacement of any individual cable with a reduction of the live load in the area where the cables is being replaced. A resistance factor  $\phi=0.75$  is suggested for this strength limit state event (Strength Limit State V in load combination table) in accordance with recommendation in Section C5.4 of PTI Guide Specification. In this case the live load is shifted away from the cable location by traffic diversions.

#### *Cable Loss Force*

The design of the cable-stayed bridge shall also be capable of withstanding the loss of any one cable without the occurrence of structural instability. The impact dynamic force resulting from the sudden rupture of a cable shall be 2.0 times the static force in cable. The resistance factor  $\phi=0.95$  is suggested for this extreme limit state event (Extreme Limit State III in load combination table). In this case the load factor of 1.1 on the cable loss force (CLF) is to account for a variation of final cable force in construction relative to the force level assumed in design.

## **2) Load combinations**

The following permanent and transient loads and forces shall be considered:

Permanent Loads

- DD = down drag
- DC = dead load of structural components and non-structural attachments
- DW = dead load of wearing surfaces and utilities
- EH = horizontal earth pressure load
- EL = accumulated locked-in effects resulting from the construction process
- ES = earth surcharge load
- EV = vertical pressure from dead load of earth fill

Transient Loads

- PP = primary prestress
- PS = secondary prestress
- SP = stay cable prestress
- LL = vehicular live load
- IM = vehicular dynamic load allowance
- BR = vehicular braking force
- LS = live load surcharge
- CR = creep
- SH = shrinkage
- CT = vehicular collision force
- CV = vessel collision force
- EQ = earthquake
- FR = friction force
- SE = settlement and construction error
- TG = temperature gradient
- TU = uniform temperature change
- TD = temperature difference between the structural components
- WA = water load and stream pressure
- WS = wind load on structure
- WL = wind on live load
- CRF = cable replacement force
- CLF = cable loss force

Load Combination Limit State		DC	DW	PP PS SP	LL LM BR	WA	WS	WL	TU CR SH	TG TD	SE	CRF	EQ	CT	CV	CLF
Strength Limit State	Strength I-1	0.9~ 1.25	0.65~ 1.5	1.00	1.75	1.00			0.5/1.2							
	Strength I-2	0.9~ 1.25	0.65~ 1.5	1.00	1.75	1.00			0.5/1.2		1.00					
	Strength II-1	0.9~ 1.25	0.65~ 1.5	1.00		1.00	1.40		0.5/1.2							
	Strength II-2	0.9~ 1.25	0.65~ 1.5	1.00		1.00	1.40		0.5/1.2		1.00					
	Strength III-1	0.9~ 1.25	0.65~ 1.5	1.00	1.35	1.00	0.40	1.00	0.5/1.2							
	Strength III-2	0.9~ 1.25	0.65~ 1.5	1.00	1.35	1.00	0.40	1.00	0.5/1.2		1.00					
	Strength IV	1.2	1.4	1.00	1.50*	1.00						1.00				
Extreme Event Limit State	Ex. Event I	0.9~ 1.25	0.65~ 1.5	1.00	0.50	1.00							1.00			
	Ex. Event II-1	0.9~ 1.25	0.65~ 1.5	1.00	0.50	1.00								1.00		
	Ex. Event II-2	0.9~ 1.25	0.65~ 1.5	1.00	0.50	1.00									1.00	
	Ex. Event III	1.10	1.35	1.00	0.75	1.00										1.10

Load Combination Limit State		DC	DW	PP PS SP	LL LM BR	WA	WS	WL	TU CR SH	TG TD	SE	CRF	EQ	CT	CV	CLF
Service Limit State	Service I-1	1.00	1.00	1.00	1.00	1.00	0.30	1.00	1.0/1.2	0.5						
	Service I-2	1.00	1.00	1.00		1.00	0.30	1.00	1.0/1.2	1.0						
	Service I-3	1.00	1.00	1.00	1.00	1.00	0.30	1.00	1.0/1.2	0.5	1.00					
	Service I-4	1.00	1.00	1.00		1.00	0.30	1.00	1.0/1.2	1.0	1.00					
	Service II-1	1.00	1.00	1.00	0.80	1.00			1.0/1.2	0.5						
	Service II-2	1.00	1.00	1.00		1.00			1.0/1.2	1.0						
	Service II-3	1.00	1.00	1.00	0.80	1.00			1.0/1.2	0.5	1.00					
	Service II-4	1.00	1.00	1.00		1.00			1.0/1.2	1.0	1.00					
Fatigue	Fatigue				0.75**											

\* Live load will not be permitted in the lane next to the cable being replaced for Strength- IV combination.

\*\* Live load will not include braking force for fatigue design

### 3) Materials

The designs should be based on the material properties cited herein and on the use of materials that conform to the standards for the grades of construction materials as specified in the Construction Specification.

When other grades or types of materials are used, their properties, including statistical variability, shall be established prior to design and verified by a specific testing program. The minimum acceptable properties and test procedures for such materials shall be specified in the contract documents.

#### 2.6.6 Design Methodology

During the preparation of the final design of the bridge the Consultant will propose a construction method based on assumed required progress of the work and assumed equipment loading. It is important to note that the Contractor needs to have a Construction Engineering Specialist for preparing the final erection design—such as step by step analysis of the tower and deck depending on timing of the working progress. Stability requirements will be satisfied by the Contractor’s working plan. Good co-operation is needed between the supervising Consultant and the Contractor. Experience from construction of earlier cable-stayed bridges has demonstrated this necessity.

The Cable-stayed Bridge will be designed according to the following methodology:

##### *Design Philosophy*

The requirements concerning a structure’s safety are formulated in relation to limit states. A limit state shall be understood to mean a state in which a structure can just satisfy a given requirement.

##### *Calculation Model*

For the cable-stayed bridge design, a 3-Dimensional frame model will be used. It is also necessary to consider the geometrical non-linear properties of the cable-stayed bridge. Due to the large displacement, 2nd order analysis shall be used in the analysis.

### *Seismic Design*

Earthquake loads shall be taken into consideration in accordance with the elastic response spectrum analysis method specified in the provisions of Vietnamese Specification for Bridge Design. The acceleration coefficient depending on the seismic performance zone will be applied to determine the design response spectrum. Site effects shall be included in the determination of seismic loads for the bridge.

### *Wind Resistant Design*

Wind tunnel test and analysis will be carried out to investigate the wind-induced behaviours of the bridge during and after construction. The methodology of the wind tunnel testing is detailed in Section 2.6.7 below.

### *Durability Design*

The latest information of concrete technology in preventing cracks during construction, corrosion problems and proper handling of concrete during the work and during the hardening of the concrete are important factors to guarantee good quality, together with reinforcement details.

### *Ancillary Design*

#### **Expansion Joints**

Expansion joints are designed taking into consideration the overall durability, surface flatness, drainability, water tightness, constructability, maintainability and economy based on the characteristics of the roadway where the expansion joints are determined, the bridge type, and applied movement range.

The movement range is a significant factor in determining the type of expansion joint. Therefore, first the type of expansion joint is determined based on movement range. Then, a device, which enables vehicles to travel on the roadway without problems even when the full movement of the girder has taken place due to temperature change, creep, shrinkage and load effects of the superstructure, should be selected.

#### **Safety Barrier**

Safety barriers are constructed in order to prevent vehicles from deviating from their course and going off the bridge as well as to minimize damage to passengers and vehicles. Guiding a driver's sight is a secondary purpose of constructing safe barriers.

The type of parapets for the bridge should be selected properly for the installation purposes and locations with thorough consideration to function, economy, construction conditions, aesthetic elements and maintenance.

#### **Inspection Facilities**

In order to inspect and maintain constructed part of the bridge on a regular schedule, inspection facilities, entrances to them and lights shall be installed taking into account the location of each bridge section, site conditions, type of structures, the height of girders



from water surface, width of deck and supporting condition of the substructure so that elements of the structure can be inspected without obstructing traffic.

Inspection facilities shall be installed in such a way so that the performance, any deterioration and defects of each part of a structure can be checked effectively.

### Other Details

FEM analysis is an important tool for analysis of areas of high and/or complex stress, such as cable anchorages in the tower and in the deck. Risk analysis of ship navigation is important leading often to special collision protection around the towers and piers in the river. Scouring analysis is important for the design of the bridge pilings. A Bridge Maintenance Manual will be prepared. It is important that the Contractor completes the maintenance plans so as to be consistent with the installed cables, bearings and expansion joints. Bridge drainage design needs special attention for the safety of traffic, for environmental reasons, and for erosion and for maintenance and repair problems of the bridge.

### 2.6.7 Wind Tunnel Test

Wind resistant design will be done by co-operation of the consultant's wind engineer, the bridge engineer, and the wind tunnel laboratory responsible for the wind tunnel testing. Equivalent static wind load approach is used to cope with wind-induced vibration of the structures and associated inertia forces. Wind resistant design starts from site review for wind and turbulence conditions by the Wind Engineer. Statistical extreme wind analysis is made based on data of the local meteorological stations by taking into account topography roughness change effects. Results are reviewed against local design standards and anticipated typhoon categories, to produce extreme wind speeds to be used for the in-service bridge and for the construction stages. This information is amended in the design bases of the bridge.

After the wind speed is agreed, the 1st set of equivalent static wind loads is given to the bridge engineer by the wind engineer to do first dimensioning of the main structures (deck & pylon). Bridge engineer will prepare detailed global 3D FE-model of the bridge, and do the modal analysis for natural frequencies and mode shapes. This information is used by the wind engineer as input to specialist software, to compute wind-induced vibration responses (buffeting and vortex-induced vibration) and the first check of aerodynamic instabilities (divergence, flutter and pylon galloping). Section-model based on the wind-tunnel results of the deck is used as aerodynamic input. Using the results, the wind engineer will produce the 2nd set of equivalent static wind loads to be used in the final structural design. Using these loads, some structural dimensions like wall thickness in pylon and number of foundation piles could be optimized. Finally, the final modal analysis information of the bridge, the specialist software rerun, and the review of full model wind tunnel testing is used to prove the wind resistant design of the bridge.



Stay-cable vibrations might be important (rain-wind induced vibration, wake galloping, parametric resonance), and are assessed separately by the wind engineer. Needs of possible additional wind tunnel testing, tube patterning, drag force etc. are written in the stay-cable specifications to stay-cable contractor to fulfil. Possible provisions for stay-cable external dampers are agreed with the bridge engineer.

Wind tunnel testing is conducted in co-operation with the wind engineer and the chosen wind tunnel laboratory. Wind tunnel testing is mainly conducted in two parts:

- 1) section model testing in the beginning stage of the detailed structural design
- 2) confirmatory aeroelastic full model testing in the final stage of the detailed structural design.

As a summary, the wind resistant design comprises the following standard issues:

- determination of design wind speeds and turbulence conditions for various wind directions and construction stages
- vortex-induced vibration (deck and pylon)
- equivalent static wind loads
- flutter stability of deck (torsional and coupled-mode)
- divergence stability (deck)
- galloping stability (free-standing pylon)
- stay-cable vibration
- assessment of possible temporary devices used during the construction.

Object of the section model testing is to provide aerodynamic input to a specialist in wind-response assessment. The assessment is based on the vibration mode shape information produced by the bridge engineer using structural finite-element modelling, and outputs wind-induced vibration responses for the all major excitation mechanisms of wind (buffeting, vortex-induced vibration, flutter, deck divergence). Using the results wind engineer compiles equivalent static wind loads to be used in bridge design by the bridge engineer. Whenever assessment indicates excessive vortex-induced vibration responses of the deck, additional section model testing will be done to design the mitigation devices (i.e. guide vanes).

Aeroelastic full model testing is done for the final design candidate. Test is conducted for in-service bridge, and wind-critical 2-3 construction stages, including:

- self-standing pylon (buffeting, vortex-induced vibration, galloping)-
- the longest cantilever stage (buffeting, vortex-induced vibration, flutter)
- in-service bridge (buffeting, vortex-induced vibration, flutter, divergence, stay cable-vibrations)

### 2.6.8 Bridge Drainage Design

The rainfall intensity for drainage design of Cao Lanh Cable-Stayed Bridge will be equivalent to the return period of 50 years.

Bridge drainage facilities play a critical role in the effectiveness of any pavement structure since bridge function relies on the condition of the drainage system. There will be an eco-friendly and efficient drainage system to prevent the runoff water to directly drain to the river. It may be a proposal to apply stormwater filtration system to the bridge. This system can filter and remove pollutants from stormwater that entrain pollutants such as garbage, sediment, organic matter prior to discharge into the river.

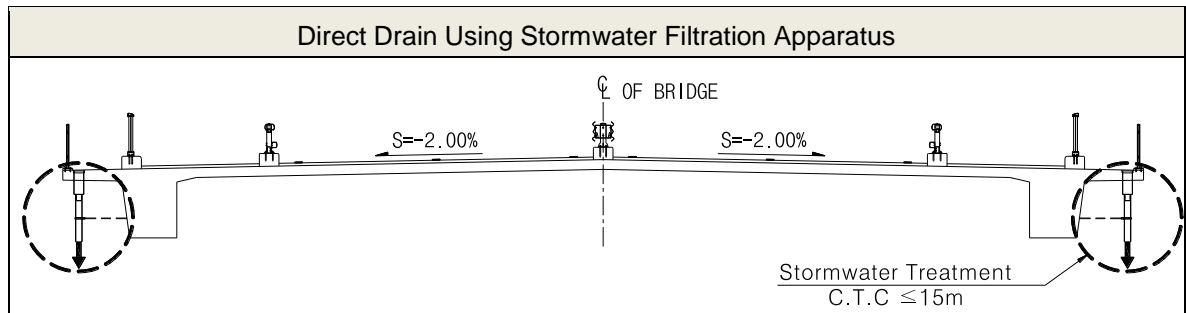

### 2.6.9 Repairing and Maintenance

The objective of the repairing and maintenance is to early find the signs before the damage happened. Regular checking in compliance with the specification shall avoid the defects, especially checking immediately after rainy season and after each storm or flood.

Regular checking the bridge will reduce the cost for repairing and maintenance. The cost of the initial maintenance is low, but when the structure becomes old, this cost will be increased more and more.

It can be suggested that types of maintenance inspection are as follows:

<b>Routine Inspection</b>	It is the inspection in daily basis. This might not be the sharpest type of inspection but this gathers the most number of information from the subject area.
<b>Periodic Inspection</b>	It is the inspection done in a chronological period(ex. weekly, monthly, etc) depending on the item concerned.
<b>Special Inspection</b>	It is an untimely inspection. This is done right after some damage is advertently or inadvertently spotted on the bridge by the maintenance personnel or by any concerned citizen.
<b>Calamity-Hazard Inspection</b>	It is the most serious type of inspection. This is conducted righter after occurrence of any calamity or catastrophe.

### 2.6.10 Construction Method

Construction of the piles, pile cap and pylon on water

- Determine the centre line of the pylon and piles
- Use specialized drilling equipment on floating system to drill holes, use clay grout and pipe casting to keep the walls stable
- Lower steel cages, pour pile concrete following the method moving-vertically the pilot pipes.

- Connect steel backing with pipe castings, install precast concrete panels with the thickness of 350mm around and under pile cap
- Break pile heads and install reinforcements and pour concrete for foundation platform with a thickness of 1m above the water
- Install tower hoist and sliding formwork, install reinforcement and pour concrete for pylon body with segment-separation method.
- Finish the pylon.

Construction of superstructure

- Constructing pylon body at pylon-girder support point, install form traveller on the pier table
- Balanced cantilevering for bridge deck with each segment cast in situ using a form traveller.
- Installing of stay cables are located at each stage
- Closing of key segment
- Installing formwork, reinforcing and pouring concrete for the curb of safe barriers. Installing expansion joints, safe barriers and illumination facilities.
- Pavement
- Adjusting stay cables

STEP 1		Construction of pier table
STEP 2		Construction of girder segments using BCM method
STEP 3		Connection of key segment
STEP 4		Completion after ancillary work and cable re-tensioning

2.6.11 Bridge Maintenance Plan and Health Monitoring

1) Bridge Maintenance

Basic Direction of Maintenance

Object	Main Point	Direction
<ul style="list-style-type: none"> <li>- High efficiency in comparison to O&amp;M cost.</li> <li>- Extension of life time through pre-cautious O&amp;M</li> </ul>	<ul style="list-style-type: none"> <li>- Develop structure system with high durability to minimize O&amp;M cost.</li> <li>- Secure space for O&amp;M considering environmental conditions, ex., a fog.</li> </ul>	<ul style="list-style-type: none"> <li>- Plan structure system with high durability at minimum O&amp;M cost</li> <li>- Set up instrumentation plan using GPS and sensors</li> </ul>

Maintenance Plan for Life Cycle of the bridge

Planning Stage	Design Stage	Construction Stage	On Service
<ul style="list-style-type: none"> <li>- Facility establishment for maintenance cost minimization</li> <li>- Inspection and instrument system for efficient maintenance</li> </ul>	<ul style="list-style-type: none"> <li>- Structural design for durability</li> <li>- Inspection facility not interrupted by cables</li> </ul>	<ul style="list-style-type: none"> <li>- Incentive instrumentation for pylon installation</li> <li>- To determine specification by initial condition</li> </ul>	<ul style="list-style-type: none"> <li>- To make maintenance plan by periodic and auto inspection</li> <li>- To establish the total maintenance system</li> </ul>

**Principal Maintenance Items**

The principal maintenance issues are to inspect and manage the pylon and the cable anchorages, to carry out measurement of cable tensions, and to check road pavement, expansion joint and bridge-deck drainage etc.

**2) Bridge Health Monitoring**

*The Needs for BHMS*

Bridge Health Monitoring System (BHMS) is the system which we can evaluate automatically evaluating safety and serviceability of a bridge as we use various high performance sensors, precision data acquisition units, broadband analogue-to-digital converters, optical or wireless networks and others. The bridge performance is lowered because of the occurrences of deterioration and damage etc. from healthy state in early completion stage according to progresses of time. Because of this time dependent characteristic, we ensure serviceability and safety of a bridge, and introduction of Bridge Health Monitoring System is increasing throughout the world in order to keep state to be healthy during life periods of a bridge.

With help of BHMS, the healthy state can be verified at the construction stage, improper construction methods and usage of wrong materials can be detected and also incompetence in construction can be identified. BHMS helps analyze the real need for structural maintenance and repair. It enables predictive maintenance by avoiding unnecessary maintenance works and planning maintenance operations of the structure in advance.

BHMS provides tools and methods of recognizing natural disasters and unexpected surprises and thus is able to generate alarms and alerts of rapid changes of the structure. Long term data storage and analysis enables the long term verification of the design.

Especially, it is hard to forecast exactly all future behaviours and construction errors are able to happen by certain factors during every construction step as cable-supported Bridges such as the Cao Lanh Cable-Stayed Bridge are composed of complicated structural components

*Objective of BHMS*

- Design verification:
  - To provide data on structural dynamic response to verify design assumptions used for the strong wind and earthquake.
  - To provide data for developing a better further design in a more rational way.
- Structural maintenance:
  - To provide data for analyzing and evaluating on the health behaviour of bridge structure.
  - To provide data for assessing structural deterioration and performance degradation.

#### *Work Scope*

##### ① Design of BHMS

- Plan of BHMS during construction and service
- Drawing of BHMS
- Bill of quantities
- Cost estimate for BHMS
- Design description and reporting

##### ② Installation of BHMS (Type-1)

- Installation of BHMS during construction
- Installation of BHMS during service
- Operating software development of BHMS during construction and service

##### ③ Installation of BHMS (Type-2)

- Maintenance manual software development of cable-stayed bridge
- Inspection drawing software development of cable-stayed bridge

##### ④ Test and Transfer for BHMS

- Sensor calibration
- Transfer and education for BHMS

#### *Strategy and Construction Process of BHMS*

BHMS is established based on the procedures shown in the figure below with the following construction strategies;

- Multiphase review considering structural features and maintenance
- Administrator-oriented system allowing convenient access and output check methods
- System design considering general customer and client's work
- System stabilization method by highly stable measurement tools, data backup system, communication network.
- Remote supervisory control system and fast recovery system
- Technical assistance considering system extension and maintenance



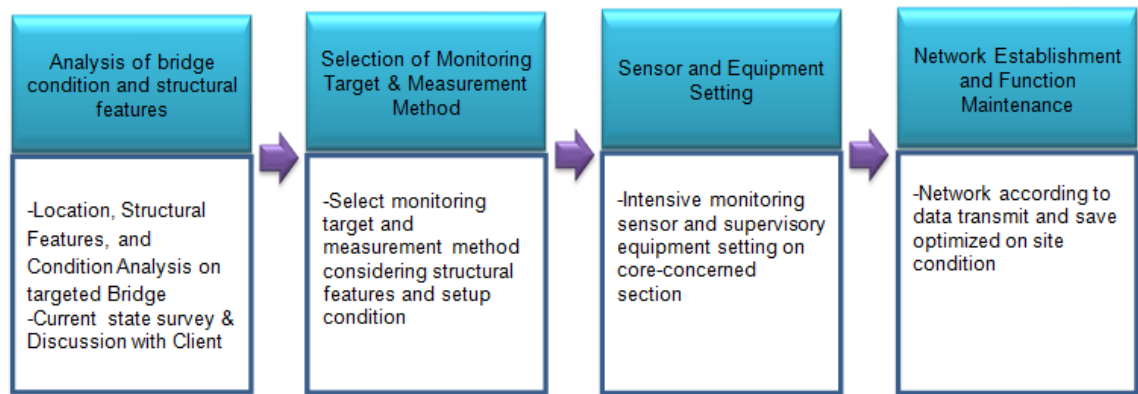

**Flow chart for BHMS installation**

*Considering Points of BHMS*

Considering a life cycle of a bridge, the following matters are reviewed for each stage of design, construction, completion, and service.

A designer sets up monitoring items during construction and operation phase in consideration of behaviours and influenced factors of a target structure and reviews the appropriate time and method for installation of hardware and software by each phase.

If necessary, a measurement manager presents requirements of the incidental facilities and electronic power for measurement, management, and others at the design stage and requests those to be included in the detailed design.

**BHMS Plan (Type-1)**

In case of the cable-supported bridge including cable-stayed bridge, it is hard to predict precisely all kinds of bridge behaviours. In addition, construction errors by various factors are caused at each stage of construction since the cable-supported bridge consists of complicated structural systems. The following Health Monitoring System is under consideration in order to carry out more organized and scientific monitoring by introducing automatic, continuous, and object monitoring technology.

- ① BHMS Composition (objective, frequency, term, and transmission method)
  - Monitoring Target: geometric shape, displacement, stress and cable tension
  - Measuring Sensor/Gauge: GPS, strain gauge, accelerometer, thermometer, anemometer, etc.
- ② BHMS Application during Construction (location, monitoring, and output analysis)
  - Construction precision check at each stage
  - Securance of Construction Safety
- ③ Bridge Health Monitoring during Construction and Service

**BHMS Plan (Type-2)**

BHMS (Type-2) is composed of maintenance manual software and inspection drawing software development so that a bridge inspector can manage systematically inspection data.

*Summary of Costs*

During the Contract negotiation meetings it was requested that a cost for providing a BHMS system should be provided and this cost is summarised in the table below.

Item	USD	Cost by Stage (USD)		
		Design	Construction	
		BHMS Design	Software Development and Installation	Test and Transfer
<b>Remuneration</b>	<b>1,908,050</b>			
<i>International</i>	<i>1,898,050</i>	<i>246,550</i>	<i>1,340,000</i>	<i>311,500</i>
<i>National</i>	<i>10,000</i>	<i>8,000</i>	<i>1,000</i>	<i>1,000</i>
<b>Out-of-Pocket Expenses</b>	<b>289,993</b>			
<b>Total (1+2)</b>	<b>2,198,043</b>			

### 2.6.12 Alternative proposals for FS design Bridge

The feasibility study gives good starting point to the detailed cross section of the bridge. Having the main span of 350m and two cable planes the open cross section is the most feasible and it will fulfill all the safety requirements. The concept in the feasibility study are reviewed, the Consultant have some opinions as follows.

#### *Pylon Cross beam*

The shape of pylon in the detail design has been studied to consider the economic efficiency as well as easy maintenance during management. The shape of pylon including lower cross beam is judged to be suitable on the whole. In a point of bridge maintenance it is very important to install inspection gantry under the girder, therefore it is necessary to have inspection gantries for every span. It means that 3 inspection gantries are installed for the entire cable-stayed bridge. By lowering the level of the cross beam it is possible for the inspection gantry to pass between girder and pylon cross beam. It means that only 1 inspection gantry is installed for the maintenance of whole bridge girder instead of 3 inspection gantries. There are many similar experiences in our design track record for cable-stayed bridges.

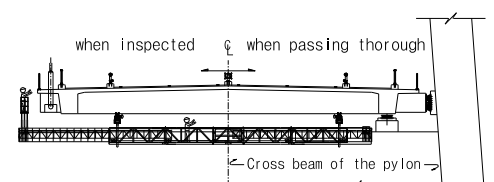
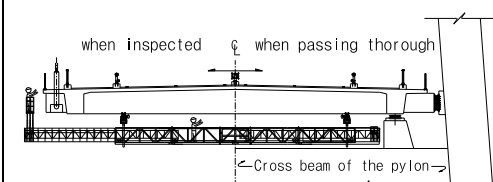
ITEM	FS	Alternative
Feature	 <p>Diagram illustrating the FS design. It shows a cross-section of a bridge girder and a pylon. The pylon has a cross beam that is positioned above the inspection gantry. Labels include 'when inspected', 'when passing thorough', and 'Cross beam of the pylon'.</p>	 <p>Diagram illustrating the Alternative design. It shows a cross-section of a bridge girder and a pylon. The pylon's cross beam is lowered so that the inspection gantry can pass underneath it. Labels include 'when inspected', 'when passing thorough', and 'Cross beam of the pylon'.</p>
Merits and Demerits	<ul style="list-style-type: none"> <li>- Inspection gantry cannot pass the pylon</li> <li>- 3 inspection gantries are needed for the full span maintenance</li> </ul>	<ul style="list-style-type: none"> <li>- Inspection gantry can pass the pylon</li> <li>- Only 1 inspection gantry is needed for full span maintenance</li> </ul>
Review	<ul style="list-style-type: none"> <li>- Just lowering the pylon cross beam guarantees the easy and convenient inspection of whole bridge girder, and economic efficiency</li> </ul>	

#### *Wind Fairing or Flap*

Aerodynamic stability is critical for the long span cable-supported bridges. The shape of the section is mainly devoted to sectional efficiency. Efficient shape of the fairing or flap will be determined after wind tunnel test.

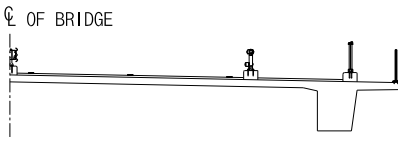
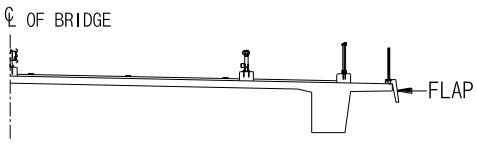
ITEM	FS	Alternative
Feature		
Merits and Demerits	- Less efficient against wind flow	- Improved aerodynamic stability
Review	- Wind fairing or flap or guide vane might be applied according to the result of the wind tunnel test.	

*Tie Down Cable System*

The FS proposed a monolithic structure between the end pier and end span of the cable-stayed bridge. The concept is to elastically absorb the end span movement at the end pier due to the live loads or temperature changes. The tie-down cable system makes the monolithic action possible, which reduces the total amount of movement by the longitudinal flexural resistance of the pier and piles.

However, a very thick end pier is required for the tie-down cable system to allow such movement and for the end pier to support the approach span together with the end span of cable-stayed bridge. Such case makes it difficult to make a continuous rigid frame structure since the stiffness of the end pier is too large. It is also obvious that this articulated system would lead to a larger amount of movement at end pier.

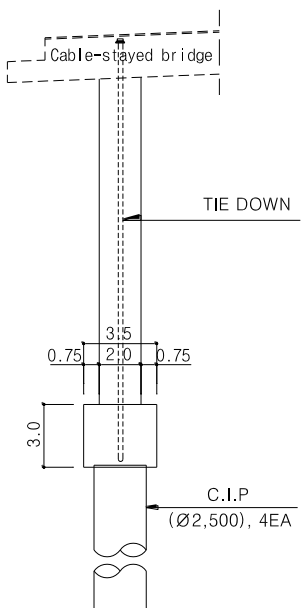
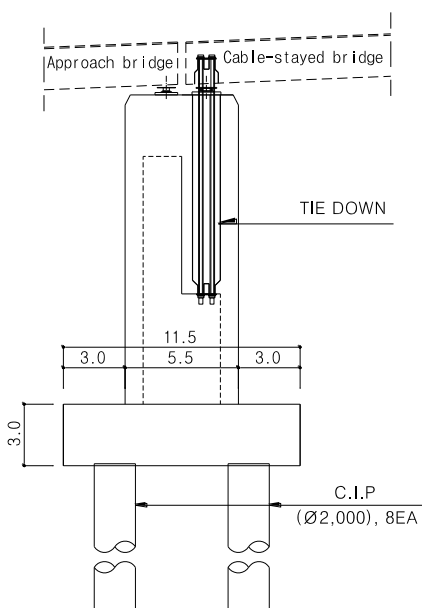
ITEM	FS	Alternative
Feature		

	<p style="text-align: center;">PLAN VIEW</p>	<p style="text-align: center;">PLAN VIEW</p>
<p style="text-align: center;">Merits and Demerits</p>	<ul style="list-style-type: none"> <li>- Monolithic action</li> <li>- Tie-down cable force may be reduced by extending the end span to approach bridge to minimize negative reaction at the support</li> <li>- Large displacement and small force due to seismic load</li> <li>- Ship collision protection is required to resist the ship collision</li> </ul>	<ul style="list-style-type: none"> <li>- Separate action</li> <li>- Stronger tie-down cable force required to minimize negative reaction at support</li> <li>- Thicker dimension of end pier</li> <li>- Small displacement and large force due to seismic load</li> <li>- Ship collision protection is not necessary if the end pier can resist the ship collision</li> </ul>
<p style="text-align: center;">Review</p>	<ul style="list-style-type: none"> <li>- Comprehensive consideration of safety and economic feasibility is required.</li> </ul>	

*Pile Cap of the Pylon*

The pile cap of the pylon is considered to avoid direct collision of a ship bow. This concept is the main factor in the planning of 80m wide pile cap, but it is thought to be quite excessive. After a data survey and a successive specification of the ship from collision analysis, an adequate size of the pile cap can be determined with a sufficient distance between the pile cap ends to the pylon legs. The size of the pile cap might be reduced under the constraint that the number of piles remains not increased.

ITEM	FS	Alternative
<p style="text-align: center;">Feature</p>		

Merits and Demerits	- Large dimension	- Optimized dimension
Review	- The dimension of pile cap might be reduced in accordance with the ship collision risk analysis, thereafter it guarantees economic efficiency	

## 2.7 Geotechnical Design and Soft Ground Treatment

### 2.7.1 Literature survey for design and construction of adjacent sites.

For earlier traffic projects in Kien Giang province, the embankment often was not treated (eg. National Highway No 80, National Highway No 60, National Highway No 61, etc.) , allowing settlement under surcharge loads. Only some of the bridges are treated by use of an approach slab on concrete piles.

The bridges on soft soil of National Highway No.63 in Kien Giang Province soft soil have treatment by sand drains of 40cm diameter.

Some projects on soft soil and treatment used in Kien Giang Province as follows:

1. So 2 Bridge Sand Drain (dia. 40cm), treatment length 15m back abutment, D=2m, Depth=9m
2. Xa Xiem Bridge Sand Drain (dia. 40cm)
3. Xeo Xu Bridge Sand Drain (F40cm)
4. Bau Mon Bridge Sand Drain (F40cm), treatment length 30m back abutment, D=2m, Depth=9m
5. Thu hai Bridge Sand Drain (F40cm), treatment length 35m back abutment, D=1.8m, Depth=8m
6. Xeo Ke Bridge Sand Drain (F40cm), treatment length 20m back abutment, D=2m, Depth=8m
7. Thu Tu Bridge Sand Drain (F40cm)
8. Xeo Buom Bridge Sand Drain (F40cm)
9. Thu Nam Bridge Sand Drain (F40cm)
10. Nhi Ty Bridge Sand Drain (F40cm)
11. Thu 6 Bridge Sand Drain (F40cm), treatment length 30m back abutment, D=2m, Depth=9m

Typical treated projects in Kien Giang.

1. 9,5 – Xeo Nhao Road An Minh Dist. (2008)  
Constructed with Pile Slab (25x25) cm, treatment length 30m from back of abutment, distance =1.8 ÷2.7m, Depth=27m
2. Cong Binh Bridges Giong Rieng Dist. (2009)  
Sand Drain (dia. 40cm), treatment length 40m back abutment, distance =1,3 ÷3m, Depth=13m

Some Projects on soft soil and treatment used in Mekong Delta River areas (not included Kien Giang Province) as follows:

1. National Highway No.1 My Thuan - Can Tho  
Constructed with (40x40)cm, length 30m back abutment, distance =1,8m, Depth = 55m  
Sand Drain (dia.40cm), L=100m, distance=1.5m, Depth =25m
2. South Hau River Can Tho – Bac Lieu Sand Drain (dia.40cm)

3. National Highway No.30 Dong Thap Province  
Sand Drain (dia. 40cm), length 50m back abutment, distance = 1.5m, Depth 15 to 18m.
4. Ho Chi Minh Highway Dong Thap Province  
Constructing Sand Drain (F40cm), treatment length 40÷60m, D= 1,5m, Depth =15÷18m
5. Quan Lo - Phung Hiep Bac Lieu Province (2007)  
Piled Slab Method on RC piles
6. National Highway No.61 Can Tho City Completed (2004)  
Sand Drain (dia.40cm)
7. Sai Gon East – West Highway Ho Chi Minh City Completed (2008)
  - DSMC (dia.60cm), D=0,5m, Depth =21
  - PVD : D=1÷2m; Depth =8.5÷28,5m;
  - Surcharge L=1,5m
  - PC Sheet Piles SW400; L=10m
  - Counterweight H=2,5m; L=21m

If possible, we would like to obtain any available performance records of these projects so that we can have better idea of the efficiency of the various methods.

### 2.7.2 Methodology for Soil Improvement :

The embankment design on soft clay has to satisfy the minimum design requirements concerning future residual settlement and stability. To satisfy the above requirement, treatment of soft soil underlying the highway is necessary, so as to accelerate the consolidation settlement of soil, to minimize the future residual settlement and to increase slope stability.

#### **Some common methods for soft soil treatment with our comment as below:-**

1. Piled Slab Method on RC piles
  - Minimize residual settlement, the effect is immediate
  - Increases slope stability
  - Easy quality control
  - Most Expensive
2. Deep soil mixed column (DSMC) and Surcharge
  - Accelerates settlement
  - Increases slope stability and ground stiffness
  - Easy quality control but expensive
3. Vertical sand drains (VSD) and Surcharge
  - Sand drains were used before paper drains were introduced and this has been carried out successfully elsewhere before and is considered workable. The diameter of the drain is from 40 to 80 cm and can be installed to more than 30m depth. Normally, sand drains are installed using a close-ended mandrel, which is driven by a vibro-hammer. Sand drains can also be installed with a bored piling rig, which is easily available, but is more expensive than vertical paper drains. However, if it is installed properly the VSD is more effective than paper vertical drains. Much more economical than DSMC but more expensive than PVD
4. Prefabricated Vertical drainage (PVD) and Surcharge
  - Vertical drain or paper with surcharge. The general size of the paper drain is around 100mm wide 3mm thick installed in close spacing from 1 m to 2 m c/c. This has been carried out successfully before and is considered the most workable. It is more economical than DSMC or VSD but not as efficient as VSD.



5. Surcharge  
Economical option, where considerable large residual settlement is allowed, or where total settlement is quiet low. Where long surcharge duration is possible it is impractical or where predicted settlement is high, considering the requirements of residual settlement and constraint in time available for the surcharge. Currently, the available soil improvement methods are as below with our comments.
6. Preloading only  
This will not normally achieve the target residual settlement due to lack of sufficient time. The degree of consolidation that can be achieved in 2 years is only around 25 to 40%. For less important structures, this may be possible.
7. Stone columns  
Very expensive and the equipment is not readily available.
8. Vibroflotation  
This has been carried out successfully by in Singapore but is very expensive and the equipment is not readily available. It is also more suitable for improving only sandy soils.
9. Vibration only –  
Not suitable because the soils contain a high percentage of silt and clay and cannot be easily compacted.
10. Dynamic Compaction –  
Involves tamping the ground surface with a drop hammer or heavy weight. Again, not suitable because the soils contain a high percentage of silt. Also the vibration may affect neighbouring buildings.
11. Complete replacement –  
Suitable for sites with shallow deposits of unsuitable deposits and their replacement with suitable material may be considered.  
Complete replacement of soft soil can also be considered for shallow deposits of unsuitable material up to 3.0m. This method would reduce the degree of settlement and time. In general, the slope of the excavation should be able to maintain a side slope of 1 vertical to 4 horizontal within the soft soil deposit and the excavation should be able to cope with the water seepage.  
Geotextiles are used to separate the soft soil from filling materials, thereby avoiding penetration and mixing of soft soil into fill material  
It increases the workability of the construction site and increases the bearing capacity of the soft soil.  
A Sand Fill Blanket makes the ground more workable for construction equipment, helps speed up construction, as there is no requirement for layer by layer compaction. It has the important function of increasing the drainage of the embankment. The sand mat must have a minimum thickness of 50cm and extend 0.5m to 1.0m on each side of the embankment.  
Lightweight fills have been used in the United States to a limited extent to reduce placement and surcharge time in soft soil conditions. Their frequency of their use in Europe appears to be increasing (it is almost routine). Expanding the use in the United States should increase availability and decrease cost, making lightweight fills such as geofoam an attractive alternative to surcharge fills and also should accelerate construction.

### 2.7.3 Soil Analyses and Monitoring

For the evaluation of the settlement,  $S$  using the equation below, we have to determine compression index,  $C_c$ , initial void ratio,  $e_o$ , preconsolidation,  $P_c$ , and overburden pressure,  $P_o$ .

$$S_1 = \frac{C_c}{1 + e_o} H \log \frac{P_o + \Delta P}{P_o}$$

Therefore in the analyses, we have to check the consolidation condition of the soil, whether it is over-consolidated, normally consolidated or under-consolidated.

For the evaluation of time of settlement, the coefficient of consolidation,  $C_v$  is the most important.

The time- settlement curves are produced together with that of combined drainage (with vertical drainage).

#### 2.7.4 Proposal for project:

Based on the above discussion, piled approach slabs can only be considered at bridge approaches. Supporting slabs will be used for the approach sections near abutment.

It is not considered for road embankment due to its prohibitive cost although it has potential to minimize settlement and also helps avoid deep-seated slope stability failure.

Same as Pile Slab, DSMC is not considered as optimal solution due to its prohibitive cost, although it has potential to accelerate settlement as well as to increase the stiffness of ground and also helps avoid deep seated slope stability failure.

VSD is cheaper than both DSMC and piled slabs. It accelerates settlement of soft ground but if the embankment height has to be constructed in many stages then it is relatively slow and it will have a critical effect on the construction schedule. A sand mat or blanket is required before placing the surcharge backfill. It is important to ensure there is no necking in the formation of sand drains that are only 40cm in diameter. It may be prudent to consider larger diameters.

PVD is similar to VSD but is cheaper. The consolidation period is slower so it will take longer to consolidate. It is very important to determine correctly the consolidation parameters in order to design the spacing of the paper drains. The FS consultant may not have had enough information during the feasibility stage to have addressed this issue.

Though economical, treatment by adequate surcharge only, is practically impossible because it takes a much longer time to be effective.

In the feasibility study, it is proposed to provide paper drains (PVD) below the berm. We will evaluate whether it is necessary to provide paper drain below the berm.

Surcharge should be in stages. If the surcharging is done too fast, it might cause soil failure and the soil will not be consolidated properly. Another effective way is to increase the overburden pressure or preloading is by reducing the ground water level by deep well points. Reducing the water level by 1m is equivalent to increasing the overburden by 10 kN/m<sup>2</sup>. Preloading by vacuum is also possible and was first introduced in Sweden and is done quite successfully in China.

Stage loading is very important but placing the surcharge at the rate of 5cm per day, as proposed in the feasibility study, is too slow. Decisions must be made on the thickness of the first lift of surcharge. The placing of the second or subsequent lift is also very important. Analyses of the monitoring record such as settlement record and the piezometer readings

should be done in order to place the second or subsequent surcharge lifts. We also need to access when the soil improvement has achieved its purpose.

Berms are proposed to increase the stability of the embankment. For a 3.5m embankment, the FS proposes a 3.0m high berm and for 4.0m of embankment, it proposes a 4.0m berm. We will evaluate the size of the suggested berms.

Preloading with extra surcharge must also be evaluated, e.g. if the actual embankment height is 4m, we may need to place a surcharge height totalling 5.0m or 5.50m. Hence, we are preloading the embankment with 1.0 to 1.50m of surcharge.

In the feasibility report, it is mentioned the end of filling would occur after 308 days, which seems too long and the end of the preloading period occurring at 408days, which seems too short.

Drains should be placed in a triangular pattern in order to achieve the best performance.

### **2.7.5 Settlement measuring data of nearby constructed sites... back analysis.**

Besides computations for estimating the settlements, which are the basis of the suggested treatment methods and embankment design on soft soil, it is necessary to use the results of observed settlements for comparing and adjusting the estimated results from computation in order to check settlement and the rate of consolidation such as the sand drain, PVD.

### **2.7.6 Influenced settlement area analysis:**

Settlement caused by the embankment self-weight creates an influence zone.

Settlement in this influence zone may cause damage in adjacent areas. According to 22 TCN 262-2000 the embankment design must ensure the settlement in the influence area satisfies acceptability criteria.

### **2.7.7 Recommendations**

Extending the length of Bridge is not considered as the optimum solution due to its prohibitive cost, although it does have advantages in technical terms.

Pile Slab is not considered as optimum solution due to its prohibitive cost. However, it has the potential to minimize settlement and also helps avoid deep seated slope stability failure. VSD is cheaper than “extend the length of Bridge” & pile Slab. It accelerates rate of soft ground, however the high embankment will consume time (due to the multi stages preloading). Combination of pile slab and VSD is solution in term of cost and time. Effect smooth at approach roads at the same time it has potential to accelerate settlement.

It is commented that the soft ground improvement measures may need to be carried out to cover Stage 2 as well. Given that the techniques may likely involve surcharge loads, it may be cost-effective to construct in Stage 1, the whole of the embankment covering Stage 2. This aspect will be further studied and recommendations made for consideration and approval.

## **2.8 Toll Collection and Central Control Facilities**

The Consultant will assist CUU LONG CIPM to get acquainted with all available tolling systems and latest related practice. The Consultant will then develop a tolling strategy for the project,

considering open and closed tolling systems (There is no decision as yet as to what is to be tolled: each bridge separately, the bridges/ connection road system) or some other combination, prepare outline designs and specifications for tolling facilities, axle load monitoring systems, and emergency warning and communications systems. It is anticipated that these will be procured, installed, and commissioned, for all project components (including Component 3A), through nominated subcontractor provisions in the contract for Component 1 but the actual method will be discussed and agreed with the Client.

## SECTION 3

# SAFEGAURDS & OTHER PROJECT REQUIREMENTS

### 3. Safeguards & Other Project Requirements

The social safeguard and gender components of the project will be undertaken by the Consultant's international and national social and resettlement specialists (SRSs) and environmental specialists.

#### 3.1 Environmental Management and Monitoring

##### 3.1.1 Introduction

The Inception Report has the main objective to determine what the Project Team intends to do in order to successfully implement the planned project.

The Project Terms of Reference (TOR) and Consortium Proposal were re-examined. The Project setting, design and implementation were reviewed via the existing project documentation prepared under the PPTA. And a short field visit was undertaken to bridge crossing points and the area through which the connecting roads will pass.

The document review and field visit checked on the Final Environmental Impact Assessment (EIA) Report and Environmental Management Plan (EMP) prepared by SMEC, in turn based on the EIA Report prepared by the Vietnam Transport Design Engineering Institute (TEDI) and to gain a direct understanding of the likely environmental issues that may ensue.

Rarely is the importance of the environmental impact on a project more important than for this CMDRCP. Today it is normal practice to consider the likely impacts of a project on the environment but in the case of the CMDRCP it is extremely important to carefully consider the likely impacts of the environment on the Project. This is particularly so with respect to potential climate change (CC), such as sea-level rise (SLR), greater local runoff, greater future water volumes and higher flood levels in the Mekong Delta.

The main issue with respect to design of bridge elevation and road embankment elevation depends on the water level in the rivers which will determine the design elevation over the international waterways of the Tien and Hau rivers and the flood level over land which will determine the design elevation of roads and bridge approaches. These elevations have not to date been thoroughly examined and made explicitly clear.

The selection of final design elevations directly affects several environmental issues and the economic feasibility and benefit considerations. Environmental management issues with respect to embankments relate to the cross-sectional profiles of the road and bridge approaches, namely that the width of the embankments depends upon their elevation of the embankments. In turn the design elevation relates directly to CC discussed in Section 3.11 of this report.

##### 3.1.2 Findings from Review of Reports

A number of reports were reviewed, namely, those pertinent to:

- The existing environmental setting and potential changes due to CC
- The project design and location



- The potential impacts that the project may have on the environment
- The prevention and/or mitigation of those potential impacts.

Several different bridge designs have been considered for the bridges over the Hau and Tien rivers, the preferred design being based on cost and ease of construction and suitability, given the environmental conditions at river crossing points. Piers will be located in the rivers and on the river banks. Environmental impacts related to river scour, aggravated flooding and sediment aggradation will require careful consideration during design.

The proposed road is currently designed to a minimum final surface elevation of +3.0m. This elevation was arrived at by considering the flood experience to date, particularly in the years 1978 and 2000 when the most recent highest floods occurred, plus the desirability of constructing a road 30cm above the expected 2050 flood level. However, it should be noted that none of the reviewed design documents assess the implications of sea-level rise (SLR) beyond 2050; the TOR require the design elevation to be above the 1% expected flood level to. This vital design issue is addressed further in Section 3.11.

Reports reviewed are listed at the end of this section. Pertinent findings with respect to the project area are summarized below.

- Tides: The Hau River is tidal inland beyond Long Xuyen. There are 2 tidal movements each day. Tidal amplitude varies 3-4m during the strong daily tide, and varies 1.5m to 2.0m during the weak daily tide.
- Annual Rainfall: Historical average annual rainfall is 1300mm to 1600mm.
- Wet season: 7 months April to November, with peak in October.
- Mekong River flow: Peaks September – November, the 3-month period accounting for 50% of annual river flow. The Tien River carries approximately 75% of Mekong River flow, the Hau River 25%.
- Road profile to date: Elevation 3m, width each side of 1m – 4m divide is as follows: embankment 3-lanes x 3.75m, shoulder 1 x 3.25m, embankment slope 1:2 slope (30 degrees) means 6m in the horizontal plane.
- The Technical Due Diligence Report (SMEC, Jan 2011) points out that (p.51) river bank scouring was assessed only for the low flood period. Perhaps this needs to be added to by an assessment for the high flood period.
- The Technical Due Diligence Report (SMEC, Jan 2011) states that (p.120) additional analysis of the extent of acid sulphate soils (ASS) is needed.

### 3.1.3 Field Trip to Road Alignment and Bridge Sites

A two-day familiarization field trip was conducted 12-13 December 2011 to site locations. Short boat trips were taken on the rivers Hau and Tien to get an idea of tidal amplitude and river bank stability.

### 3.1.4 EIA Report and Environmental Management Plan (EMP)

The EIA Report (SMEC, Jan 2011), was based on an EIA Report by TEDI and additional investigations. It is a thorough assessment of the environmental setting, the project, likely impacts and their mitigation. It meets or exceeds ABD and Vietnam requirements.

The only requirement for supplemental EIA work relates to road embankment and bridge approaches. There are two issues: a) the volume of topsoil to be, including acid sulphate soils (ASS), and b) the volumes of materials required to construct the embankment and bridge approaches. These volumes need more careful assessment and depend upon the final elevation of the embankment. The final design elevation is a vital and urgent matter requiring immediate attention.

ASS requires special handling and disposal. The acid leached from ASS can reduce water quality, kill fish and plants and reduce soil productivity. Additional attention to the removal, handling, treatment and permanent storage/disposal of ASS is required and the method to handle then needs to be finalized. The environmental issues related to ASS handling will be finalized at the same time and changes (if any) will be made as required to the EIA Report and EMP.

The EIA Report and EMP to date do not address asphalt plant location, operations and site restoration. This will be addressed during the Design Period.

Linked to the EIA Report is the EMP. It is complete with the exception that the environmental management of asphalt plants was not addressed.

The EMP to date will be consolidated and revised to become more user-friendly and shorter so that it may be summarized in a form suitable to be included in the Contract Documents Package.

As each contractor has the responsibility to prepare a Construction EMP (CEMP), a CEMP Guideline will be developed to assist contractors.

### 3.1.5 Assist CUU LONG CIPM with Environmental Management

Orientation of National Environmental Specialist (NES)

The NES is scheduled to commence Project work at the end of February 2012. The International Environmental Specialist (IES) will assist the NES to become familiar with Project documents, the EIA Report and EMP as prepared and the requirements for environmental management of the Project.

Assist CUU LONG CIPM with Organization Management of Environmental Management (EM) Unit

The IES, assisted by the NES, will assist CUU LONG CIPM to:

- Define organizational and staffing requirements to undertake environmental management of transportation projects in general, focusing on the performance monitoring of the CMDRCP;
- Prepare job descriptions for staff positions to be created;
- Assist CUU LONG CIPM with staff recruitment. **Note:** Staff recruitment will have to be completed before environmental training can be undertaken.

Develop Environmental Training Program (Delivery during Project implementation)

The CMDRCP is required to prepare an environmental management training program and provide training to CUU LONG CIPM and key contract staff. The tasks involved include the following:

- Identify the levels of understanding among the people to be trained (by conducting guided face-to-face and group interviews with pertinent CUU LONG CIPM staff);
- Prepare interview guide for Environmental Training Needs Assessment;
- Conduct a Training Needs Assessment among appointed CUU LONG CIPM staff and identify the gaps in understanding (against the level of required knowledge and perspective);
- Design a suitable Training Program and Plan to provide 2-weeks of initial training.

### 3.1.6 Environmental Management Work Plan

Month	Tasks	Outputs
1	<ul style="list-style-type: none"> <li>➤ Review documents</li> <li>➤ Visit work sites and bridge crossing points</li> <li>➤ Environmental input to Inception Report (IR)</li> <li>➤ Environmental input to Design</li> </ul>	<ul style="list-style-type: none"> <li>➤ Completed section 3.1 of Inception Report</li> <li>➤ Prepared notes on issues to be addressed during months 4-6</li> </ul>
4 & 5	<ul style="list-style-type: none"> <li>➤ Orientate/Train National ES as necessary</li> <li>➤ Consider implications of geotechnical, hydrological and other findings and chosen methods to handle acid soft-soils (ASS)</li> <li>➤ Complete review of pertinent reports and reports</li> <li>➤ Re-assess and finalize probable project impacts and their mitigation, and prepare Final/updated EMP</li> <li>➤ Meet MOSTE/DONRE re: EMP and gain their approval</li> <li>➤ Environmental input to Design</li> <li>➤ Assist CUU LONG CIPM with organization and staff position job descriptions for environmental management by CUU LONG CIPM</li> </ul>	<ul style="list-style-type: none"> <li>➤ Final EMP</li> <li>➤ Final EMP approved by MOSTE/DONRE</li> <li>➤ CUU LONG CIPM Environmental staff job descriptions</li> </ul>
9 & 10	<ul style="list-style-type: none"> <li>➤ Finalize Monitoring Program</li> <li>➤ Adapt Final EMP and Monitoring Program as needed for Procurement Package</li> <li>➤ Prepare Construction EMP (CEMP) Guideline to assist contractors when preparing their CEMPs</li> <li>➤ Conduct Environmental Training Needs Assessment in CUU LONG CIPM Prepare Environmental Baseline Report (basis for quarterly reporting)</li> <li>➤ Complete Final Environmental Management Training Program</li> <li>➤ Prepare Public Consultation and Information Disclosure Plan</li> </ul>	<ul style="list-style-type: none"> <li>➤ EMP adapted and included in Procurement Package</li> <li>➤ Environmental Monitoring Program</li> <li>➤ Identified environmental training needs of CUU LONG CIPM staff</li> <li>➤ Environmental Baseline Report</li> <li>➤ CEMP Guideline</li> <li>➤ Public Consultation and Information Disclosure Plan</li> </ul>

#### Documents Reviewed

- Annex 7: Environmental Impact Assessment (EIA), Final Report, SMEC, Jan 2011
- Annex X: Social Impact Assessment, Final Report, SMEC, Jan 2011
- Annex Y: Economic Feasibility Assessment, Final Report, SMEC, Jan 2011

- Feasibility Study: Vol.II.I – Cao Lanh – Vam Cong Connecting Road, TEDI and several other design feasibility studies
- Climate Risk and Adaptation in Asian Coastal Megacities – a Synthesis Report, World Bank, Sep 2010
- CMDRCP Proposal, by WSA/WSP/Yooshin Joint Venture, May 2011
- ADB Safeguards Policy Statement, Jun 2009
- ADB, Contents of Environmental Management Plan

### 3.2 Resettlement

#### 3.2.1 Background

The inventory of losses (IOL) survey was carried out between October and November 2009. There are four wards/communes in Dong Thap Province that will be traversed by the Project. Following the IOL, the involuntary resettlement (IR) impacts were reduced through revisions to the project design (reduction in width of the safety corridor and exclusion of parking areas associated with the two interchanges and toll plaza). Two construction yards were added to the land acquisition requirements with an estimated four hectares (ha) each.

IR impacts, based on the IOL and estimation of impacts associated with the construction yards, are anticipated to be in the order of that shown in the following table.

**Table – Estimated Involuntary Resettlement Impacts**

Project component	Estimated impacts			
	No. of affected households (AHs)	Area of land (ha)	No. of affected businesses	No. of affected houses
1	767	53	26	399
2	558	93	3	122
3	126	19	1	40
Total	1451	165	30	561

It should be noted that affected household (AH) has the same meaning as displaced household under ADB’s IR safeguard and includes enterprises, institutions and business operations.

During the project the resettlement activities will include: (i) updating the resettlement plan(s) (RP); (ii) preparing a livelihood and income restoration program; and (iii) supporting sufficient and adequate implementation of the RP to allow the commencement of construction activities.

The Consultant will undertake the tasks precisely as required under the ToR.

#### 3.2.2 Updating the Resettlement Plans

Following completion of the detailed design, the IOL can be updated based on a detailed measurement survey (DMS), this will allow updating of the RP already prepared for each district. The DMS will be undertaken on the basis of the extent of the works being marked on the ground (demarcation) to provide an accurate accounting of losses and impacts to be experienced by each household. The DMS will include questions on the socio-economic characteristics of the AHs so that detailed information can be fed into the livelihood restoration program (LRP).

The SRSs will work with the Compensation, Assistance and Resettlement Committees (CARCs) established at district level, non-government organizations (NGOs) and civil society organizations (CSOs) such as Women’s Union, Youth Union and Fatherland Front as well as commune/ward leaders to identify the poor and vulnerable AHs and measures for their support and assistance during the RP updating process. These measures will form part of the LRP (discussed further below) to be devised to assist significantly affected and/or relocating AHs.

The most recent official rates established by Dong Thap Provincial People’s Committee (PPC) compared with rates obtained through a market rates appraisal and consultations will determine the replacement costs at current market value to be used as the basis of compensation cost calculations and compensation awards.

The updated RPs will need to carefully address temporary IR impacts, in addition to the permanent and significant effects. Temporary impacts will be created largely during the construction stages of the project, with land parcels belonging to small farmers potentially being required for staging works, stock-pile areas, work yards, etc. during construction activities. While impacts on small and marginal impacts will be minimized through careful placement of works/plant, if impacts do occur they will need to be mitigated. The project’s entitlement matrix will need to be checked, but it is usual to include an entitlement for mitigation of temporary impacts; this is by way of the project paying a rental for the land used (for at least a year) and restoration of the land to its former productive value and quality. If the latter cannot be achieved, or the project requires the land for more than a year the farmer will be given the right to sell the land to the project (for either cash compensation or replacement land as required by the affected party).

In addition the RPs should address any livelihood impacts identified during the IOL or the social impact assessment (SIA) or subsequently captured in the DMS. It has been noted that following construction of the bridge the livelihoods of people living /working near the Cao Lanh ferry will be severely impacted once the bridge becomes operational and the ferry is no longer used. At present income and livelihoods of many traders are based on the ferry - when the Project is finished, their lives/income will be affected. The SIA and RPs prepared for the project will be reviewed to see how this issue, and any others, is dealt with, if required a survey of people with livelihoods affected in this way will be undertaken and mitigation of such impacts will be included in the LRP in the relevant RP.

The updated RPs will need to be endorsed by ADB, this will be the trigger for implementation of the RPs. As the RP implementation process has already commenced in some districts, it will be important to assess the conformity of activities with the RPs and to identify lessons to be learned and incorporate these into the RPs to be updated.

### 3.2.3 Livelihood and Income Restoration Programs

Compensation alone is not sufficient to meet the objective of the IR safeguard which is to, at least restore, if not improve, the livelihoods and living standards of AHs. This means that a LRP addressing impacts on incomes of farmers who lose a significant amount or all of their agricultural land, or business operators/shopkeepers who must re-establish at a new location are addressed in a comprehensive and appropriate manner. ADB’s IR safeguard defines a “significant” impact as loss of 10% or more of productive (income generating) assets. Decree 197 defines a significant loss of 30% or more of productive land. The entitlement matrix and RPs

already prepared, and if a resettlement framework was prepared for the project, will be consulted to ensure that the definition to be applied in the project is acceptable to both ADB and MOT.

Livelihood restoration measures, including those identified in Decree 197, will be designed to assist severely affected households to restore their pre-project living standards and productive incomes, along with measures that will enable poor and vulnerable households to improve their livelihoods and wellbeing.

The project documents prepared to date note that due to a scarcity of agricultural land in the project area, replacement land will generally not be possible as a form of compensation. Therefore along with cash compensation for land to be acquired for the project, farming AHs will need support and training (skill building etc) to transition to alternative livelihoods.

The RPs note that some alternative livelihoods were identified during initial consultation with AHs: poultry-raising, pig-breeding, cattle-rearing, aquaculture, and development of small or household businesses. However, a number of these still rely on land being available. Further consultation will be required to ascertain the general skill and education level of AHs (by members) in order to start identifying suitable alternative livelihoods and the training necessary Assistance during the transition will be required, and this will need to be identified in consultation with the AHs and CARCs. Local organizations have been identified to develop components of the LRP, the proposals will be reviewed by the SRS after consultations with AHs. A procedure to follow-up the progress of income restoration will be prepared and this will also be integrated into the RP and overall project monitoring.

### **3.2.4 Establishment of the Payment Process**

As specified in Decree 197 it is a responsibility of the CARCs to award and monitor compensation payments. This will be monitored internally by the project (SRS) and by the external monitoring organization (EMO).

The SRSs will assist MOT/CUU LONG CIPM in setting up a system to ensure that channelling and disbursement of funds are done transparently, efficiently and effectively, and suitable monitoring mechanisms are in place; this will allow timely submission of the resettlement audit reports.

### **3.2.5 Strengthening Effective Coordination**

Due to the number of agencies involved (SRU, CARCs, EMO) there is a need for strengthening of the interface between the CUU LONG CIPM and the other agencies, including lines of communication. Overall the Consultant will work to ensure that communications are coordinated and follow established protocol for MOT projects.

In respect of resettlement activities, the SRSs will be responsible for establishing systems and a process for allowing a smooth flow of information between AHs (ward/commune), CARCs, provincial government agencies as required and SRU and MOT/CUU LONG CIPM .



### 3.3 Indigenous People (Ethnic Minorities)

#### 3.3.1 Background

ADB's indigenous people (IP) safeguard policy refers to people which include ethnic minorities. In Viet Nam, in addition to the Kinh group which accounts for 86% of the population, there are 53 other ethnic groups, the largest of which include Tay, Thai, Muong and Kho-me each with populations of about 1 million. In Viet Nam, all Vietnamese are considered indigenous, therefore, in context of the ADB's IP safeguard the preferred term is ethnic minority people, and that is the terminology used in project documentation.

There are two ethnic minority groups in the Mekong Delta; Khmer and Cham, of which the Khmer are more numerous. There are approximately 1.05 million Khmer in the Mekong Delta accounting for around 7% of the total population, and being concentrated in the Provinces of Tra Vinh (30%), Soc Trang (29%), Kien Giang (13%), and An Giang with smaller numbers in Bac Lieu, Can Tho, Vinh Long and Ca Mau.

Ethnic minorities specific actions (and gender strategy) are included in the RPs, i.e., active participation of women and ethnic minority people from consultation through to monitoring, representation of women and ethnic minority people on compensation committees, capacity-building targeting women and ethnic minorities, information dissemination and disclosure in a form appropriate to different ethnic groups (and recognising different literacy and education levels of some ethnic minority groups and women), and identification of monitoring indicators dis-aggregated by sex and ethnicity.

A strategy to address resettlement of affected ethnic minorities has been prepared and is presented as a combined RP and EMDP (REMDP). The main objective of which is to ensure that affected ethnic minority households will benefit from the project and will not be adversely affected.

#### 3.3.2 Integration of Ethnic Minorities Issues in Resettlement Activities

In all the resettlement activities, specific attention will be paid to ethnic-minority AHs. Resettlement activities will be undertaken with respect for ethnic minority people recognising any specific or unique needs they may have associated with language differences or cultural values.

As many ethnic minority AHs will lose significant proportions of productive land, special measures will need to be identified and included in the LRP. Specification attention will be paid to the poor and vulnerable households belonging to ethnic minorities, as well as ethnic minority AHs headed by women.

#### 3.3.3 Institutional Roles and Organization

The SRSs will assist MOT/CUU LONG CIPM and the SRU to ensure that all the activities included in the REMDP will be carried out. In particular they will first ensure that provincial and district CARCs include representatives from the provincial Committee for Ethnic Minorities and Mountainous Areas (CEMMA) and Fatherland Front.

Within SRU (based in HCMC), at least one staff member will be responsible for implementation of the strategy to address resettlement impacts on ethnic minority AHs. Within SRU, this person

will be the resource-person for the ethnic minority issues for the whole project. All SRU members will be trained on ethnic minority issues (refer to capacity building section below).

### 3.4 Social Development and Gender Issues

#### 3.4.1 Background

The SRSs will also be responsible for implementation of the social development plan (SDP) prepared for the project. The SDP covers a range of poverty, ethnic minority and gender issues that need to be properly addressed during implementation of the project. The SDP includes; (i) mitigation of local construction stage social impacts (such as noise, dust, access issues etc.); (ii) activities linked with the actions for the poor and ethnic minorities identified in the RPs (if required); (iii) gender strategy; and (iv) contractor and community awareness and prevention on HIV/AIDS and human trafficking.

#### 3.4.2 Poverty Issues

The project area is located in two provinces in the Mekong Delta; Dong Thap and Can Tho, with most of the project being located in Dong Thap. The area is located in the centre of the Mekong Delta with Tien Giang to the north, Vinh Long to the east, Ca Mau and Kien Giang to the south and An Giang to the west. Traditionally agriculture and especially rice production has been the mainstay of the Mekong Delta economy though over the past two decades there has been a steady increase in the industrial sector concentrated mainly in Ca Mau, KienGiang, Can Tho, TienGiang and An Giang.

The incidence of poverty in the Mekong Delta region is below the national average and ranks favorably against virtually all other regions in the country. Poverty is not distributed evenly in the Mekong Delta, with significantly higher average poverty rates experienced in Soc Trang, Tra Vinh and Ben Tre provinces.

Information provided in the SIA and the data to be recorded in the DMS will provide an estimate of poverty rates in the project area. Issues for poor households in resettlement will be addressed through the LRP. Poor households not affected by resettlement (beneficiary households) will participate in the implementation of, and gain benefits from the SDP.

Adverse social impacts that could disproportionately affect poor households will be addressed as discussed below.

#### 3.4.3 Mitigating Social Impacts

The SIA identifies a number of social impacts, most of which will occur during construction. While an environmental management plan (EMP) will be implemented that will deal with most, if not all of the consequences of construction, the SDP will also ensure mitigation of impacts on poor, ethnic minority and other vulnerable households.

Social impacts are expected to relate to works impacts causing nuisance (noise, vibration, dust), run-off and drainage containment, traffic safety and operations, damage to or impact on economic activities, access and safety concerns and damage to agricultural land and the temporary use of land (and associated compensation issues). These issues will be addressed through the EMP and RPs (temporary and livelihood impacts).

More significant issues include the potential risk of spread of communicable disease, especially HIV and sexually transmitted infections (STIs) through the presence of a large work camp, and risk of trafficking associated with opening up transport corridors (discussed in detail below).

#### 3.4.4 Gender Issues and Strategy

The project's gender strategy addresses gender specific impacts and includes measures to mitigate adverse impacts on women and female headed households. The updated RPs will specifically address resettlement impacts and identify any additional measures required to ensure that women and female headed households are not made vulnerable as a result of IR impacts.

Similarly the risk of spread of HIV and STIs and potential risk of trafficking can have disproportionate impacts on women and girls, and as such will be accorded due emphasis in the program designed to mitigate these risks (refer below).

### 3.5 Communicable Disease, Trafficking Awareness and Prevention

An Giang and Can Tho have amongst the highest provincial HIV and STI rates in the country. An Giang, being a border province, has added concerns and issues related to a highly mobile population (in and out migration) and a potential trafficking route.

The influx of workers during the construction phase will bring the local population into contact with a larger number of people and will increase the risk of disease propagation, STI's and HIV/AIDS being of major concern. During its operation, the highway as a transport corridor could become a new pathway for disease and potentially also a trafficking route. For longer projects, offering access to areas previously restricted by lack of roads, mobile groups such as truck and bus drivers are particularly vulnerable and constitute a conduit for the propagation of such diseases. But, fortunately, due to the highway's limited length and the limited changes in travel patterns at the macro level, this is not considered to be a major issue for this project.

The Consultant's team includes an international HIV specialist (IHS) who will work with an approved service provider to implement an awareness and prevention campaign and carry out the following specific tasks during the construction supervision period:

- Prepare an HIV/AIDS prevention Program, including propaganda campaigns, and submit these to MOT/CUU LONG CIPM for approval.
- Conduct an HIV/AIDS prevention Program, including propaganda campaigns, for the Project-related personnel, and for local community members to join in.
- Ensure that Consultant employees participate in the HIV/AIDS prevention activities.
- Ensure that Contractors, their employees, subcontractors and their staff participate in the HIV/AIDS prevention activities
- Prepare and submit the HIV/AIDS program activities monitoring report quarterly
- Recommend any additional HIV/AIDS program where considered necessary.

The IHS will be supported by a national specialist with prior experience in implementing HIV/AIDS awareness and prevention programs at the community level. The Consultant will work in close liaison with MOT/CUU LONG CIPM , and Standing Provincial AIDS Committees, Provincial Health Departments and Women's Unions, etc., in order to strengthen their institutional

capacities and assist in implementation of the HIV/AIDS awareness and prevention program in project communities and construction camps .

In conjunction with a specialist sub-consultant (approved service provider), the IHS will develop the tasks set out in the TOR and address the following specific aspects/issues:

- Conduct a needs assessment and outline a capacity building training plan for MOT/CUU LONG CIPM , Provincial and District Health Authorities, Women's Union and other CSO;
- Design the HIV/AIDS awareness campaign and training programs based on review of the campaign materials prepared by Action Aid, CARE International and other development partners. The campaign materials of these projects will be adopted as applicable for the Project;
- Coordinate with the SRS in terms of addressing gender and ethnic minority issues in the awareness and prevention campaign;
- Develop a program for community level peer educators for community mobilization and awareness on HIV/AIDS; developing community level groups for community monitoring;
- Prepare an advocacy action program on HIV/AIDS/STIs through the Women’s Union and CSO. The program will cater specifically to the needs of the communities along the project road as identified in a rapid assessment exercise. (The rapid assessment will include number of population, current awareness of HIV/AIDS, number and types of mobile population, numbers and types of entertainment facilities (bars, food stalls, etc.), number and type of transport services, number of sex workers or service women, numbers of police and health workers, etc.);
- Advise on specific contract clauses (i.e. standard FIDIC clauses) in respect of contractor obligations for implementation of awareness and prevention for construction workforce;
- Prepare a plan for the provision of HIV/AIDS and STD medical packages to clinics and medical centres along the right-of-way; and
- Advise on any project performance monitoring indicators on HIV/AIDS/STDs prevention as required for the project monitoring.

The HIV and STIs and trafficking awareness and prevention campaign will be initiated immediately on mobilization at the commencement of the civil works. The campaign will involve the women’s union, youth union, health workers, female community leaders and members, and men and women from affected households. Mobile groups will also be targeted.

For maximum impact, an approved service provider such as CARE, FHI or World Vision, due to their experience in the area, will be invited to participate in implementation of the campaign.

### 3.6 Training and Capacity Building in Social Safeguards

Training and capacity building of the agencies involved in resettlement at the central level (SRU) and at the local level – CARCs - will be an important task of the SRSs during the course of the project. Even if MOT/CUU LONG CIPM to date has gained considerable experience on ADB social safeguards, gender and poverty issues, there is still a need to strengthen these abilities.

During the design phase, the SRSs will undertake a training needs assessment (TNA) of SRU, MOT and CUU LONG CIPM and NGOs and CSO to participate in aspects of resettlement or implementation of the SDP in order to design an appropriate safeguards training and capacity building program. Delivery of the training will be through workshops/clinics held for SRU and

MOT/CUU LONG CIPM staff and on-the-job (OTJ) training for CARCs and CUU LONG CIPM safeguards and gender specialists.

In respect of resettlement, the training needs to focus on similarities and differences between Decree 197 and ADB's IR safeguard, RP preparation, updating and implementation, and identification of livelihood restoration needs and translation of the same into an implementable program. Social development issues – integration of poverty, gender and vulnerability issues, addressing HIV/STIS and trafficking awareness and prevention – will be incorporated into the training program.

For ethnic minority development, capacity-building (based on the TNA undertaken during the design stage of the project) will be developed for SRU's members, provincial and district CARCs, local leaders including representatives of the CEMMA in each province (and district level where required) and the EMO. The Fatherland Front is the CSO with a mandate for protecting and assisting development of ethnic minority people. This CSO will be invited to participate in consultations, preparation and delivery of the LRP, and any capacity-building aimed at ethnic minority AHs.

### 3.7 Project Performance Monitoring

The consultant will develop systems and programs that will enable performance with regard to project implementation to be monitored and the impacts of the project relative to those expected to be assessed. Specifically, the consultant will:

- (i) provide and maintain a computerized project management system that will assist CUU LONG CIPM to implement the project and provide information on project progress for routine reports, review missions, and PCC meetings;
- (ii) prepare a monitoring and evaluation program (similar to the monitoring and evaluation framework and program developed for the adjacent ADB/AusAID supported Southern Coastal Corridor Project) that will enable the effectiveness of implementation activities for all components of the project to be assessed, giving particular consideration to (a) the precise description, timeliness, cost and quality of physical infrastructure implemented in the project, (b) the integrity of resettlement and related programs, (c) the effectiveness of capacity building activities, and (d) the extent to which the project's Social Action Plan is implemented as planned and its impacts;
- (iii) submit the proposed monitoring and evaluation program to CUU LONG CIPM and, through CUU LONG CIPM, to ADB and AusAID for review and approval; and
- (iv) implement the approved monitoring and evaluation program using 'before' and 'after' studies and other forms of survey and analysis, giving regard to the project's anticipated effect on economic and social development as indicated in the Design and Monitoring Framework for the Project including (a) per capita income in the project provinces, (b) the volume and type of freight and number of passengers using the road network in the project area, (c) passenger and freight vehicle operating costs on the project road and on the project area road network between key locations, (d) tariffs for freight and passenger movement between selected locations that indicate the impact of the project on target groups in the community, (e) the quantity and type of traffic on roads that form the network within which the project road will be constructed; (f) the origin and destination of vehicles and traffic at selected locations within the project area, particularly at the

Cao Lanh and Vam Cong ferry crossings; and (g) the effectiveness of capacity building programs for CUU LONG CIPM staff associated with the Project.

To commence the performance monitoring activity, which will be done under the detailed design part of the services, the Consultant will conduct socio-economic and baseline surveys. The Consultant will assemble appropriate data, including data obtained during PPTA implementation and from other similar and relevant studies undertaken with the project area, and carry out such additional socioeconomic and other baseline surveys that are required to ensure that the project's impacts can be effectively identified and monitored. Specifically, the consultant will:

- (i) ensure that monitoring and evaluation specialists liaise with all other technical staff to develop and implement a comprehensive and effective monitoring and evaluation program;
- (ii) establish systems for recording data and statistics for such monitoring;
- (iii) design surveys and identify the collection of other required data needed for the monitoring and evaluation program, drawing on for example traffic and travel surveys, household socioeconomic sample surveys, participatory rapid appraisals, social and environmental impact assessments and indicators, and secondary data from government sources. Where relevant, indicators shall be disaggregated by gender and socioeconomic status;
- (iv) produce baseline and subsequent reports; and
- (v) evaluate the benefits of the project at completion in accordance with a schedule and terms of reference to be mutually agreed by CUU LONG CIPM and ADB prior to project completion.

### 3.8 Anti-Corruption Action Plan

Throughout the project, the consultant will assist CUU LONG CIPM with implementing and administering the project's anti-corruption action plan, which will have been prepared separately by CUU LONG CIPM with ADB and AusAID assistance. This task will include setting up and maintaining a website, as part of the overall project website. In the event that the Government agrees to include the project in the on-going Construction Sector Transparency Initiative (CoST) program in Viet Nam, the consultant will assist CUU LONG CIPM with meeting the reporting and other requirements that the program requires (refer to [www.constructiontransparency.org](http://www.constructiontransparency.org) and <http://www.minhbachxaydung.org.vn/CoST/>).

### 3.9 Training (Technology Transfer)

#### 3.9.1 General

The Consultants can offer a multitude of diverse experiences in training government staff members from newly industrialized and developing countries. For the successful implementation of the project and the improvement of their professional skills, the Consultant will conduct training program for MOT/ CUU LONG CIPM staff for the technology to be used in bridge and pavement design, the construction methodology, and other specialized procedures.



### 3.9.2 Advice and on-the-job training

The Consultant will undertake on-the-job training to - Promote technology transfer to MOT/ CUU LONG CIPM staff; Reduce the dependence of MOT/ CUU LONG CIPM staff in foreign technical assistance; Improve the individual performance of MOT/ CUU LONG CIPM staff.

### 3.9.3 Overseas on-the-job training to delegates of the Client

A key feature of our technology transfer will comprise a study tour to the Korea for senior management staff members of CUU LONG CIPM /MOT to study large span Cable Stay Bridge design, supervision and maintenance. The tour will comprise a 10-day visit to various key places of interest in Korea for ten (10) members of CUU LONG CIPM /MOT senior management. The Tour will be led by senior experts from WSA-WSP-Yooshin.

A second tour of ten (10) members of CUU LONG CIPM /MOT senior staff to USA will be offered - WSA have particular strength in state-of-the-art ITS for Expressway systems and opportunity will be afforded to demonstrate the key features and effectiveness of such systems. WSA's expertise extends to both open and closed tolling systems and opportunities will be available for CUU LONG CIPM /MOT to gain an insight into their applications from their USA counterparts in expressway design, construction, maintenance and tolling operations. The PSC's previous experience in such issues will prove invaluable.

### 3.9.4 Environmental and Other Social Safeguards Training Program

In light of the significance of the environmental issues on this Project and other social safeguards, the Consultant will design and implement a training program on environmental and social safeguards. The Consultant will work with the Project Director to carry out a needs assessment for environmental inputs to project implementation; develop a staffing structure for the environmental positions and a schedule for its implementation; prepare ToRs for the environmental positions and assist with recruitment; develop help build capacity and procedures in undertaking analyses of environmental impacts of road projects in accordance with Government regulations and donor guidelines.

The envisioned capability enhancement for this project consists of two components. The first component targets the CUU LONG CIPM environmental staff and the Contractor. This training will consist of:

- i. EMP orientation:
  - The environmental management plan,
  - Mitigation,
  - Monitoring, and
  - Public consultation.
- ii. Monitoring Data Collection and analytical methods.
- iii. Environmental Data analysis and interpretation and data archiving.

The final content of this training for CUU LONG CIPM and Contractor shall be finalized during the detailed design stage after a need assessment has been carried out. The training shall incorporate the learn-as-you-do technique. It shall be a two week program with a refresher course on the second year of project implementation. Training shall be conducted by the CSC using one international expert and one national environmental expert.



The second component is the orientation of the affected persons. This shall be carried out as part of the information disclosure and public consultation. This shall be jointly conducted for social impacts, resettlement and environment for affected persons in the two Provinces.

### 3.10 Reporting

The Consultant will produce reports and documents precisely in line with the TOR. Further reports will be provided as agreed. The reports identified for the Detailed Design and Procurement stage are shown in the table below, together with their submission dates:

Deliverable	When	Date
Inception Report (Detailed Design Part)	End of month 1	24 December, 2011
Geotechnical and Soil Investigations Report	End of month 3	24 February, 2012
Interim Report	End of month 4	24 March, 2012
Final Updated Resettlement Plans	End of month 6	24 May, 2012
Updated EMP and /or new/supplementary environmental assessment report (if necessary)	End of month 6	24 May, 2012
Draft Design Report for Cao Lanh Bridge and Interconnecting Road (to be submitted for proof check)	End of month 7	24 June, 2012
Draft Final Report – Detailed Design Part (will include all designs and resettlement plans, EMPs, bidding documents and Social Action Plan)	End of month 10	24 September, 2012
Draft Final Report – Procurement Support Part	End of month 16	24 March, 2013
Final Report – Detailed Design	1 month after comments on DFR	
Environment, Social and Performance Monitoring Report 5 3 baseline report 3 month before the start of construction and quarterly updates, included in the monthly report for the period	Baseline report 3 months before start of construction.	
Progress Reports	Monthly	24 <sup>th</sup> of each month
PCC Report	Quarterly	

### 3.11 Climate Change

#### 3.11.1 Objective

Identify potential climate change (CC) vulnerabilities and develop options for:

- a. Climate proofing the project, and
- b. Seeking additional financing for the incremental cost of such climate proofing.

#### 3.11.2 Background

Climate change (CC) effects on the CMDRCP relate to flood water-levels (fresh and saline), rainfall intensity, flood-water runoff, and the length of time that flood-water may cover the land around road embankments and bridge approaches.

From the CC reports reviewed to date and the nature of water flows in the Mekong Delta it is reasonably clear that:

- Rainfall and, hence, runoff can be expected to increase significantly in the Mekong Basin and Delta area.
- Flash floods are expected to increase in frequency and intensity and have significant effects in the head waters of the Mekong River but little effect in terms of flash flood effects in the Delta, however, river volumes are expected to increase accordingly, particularly in the wet season.
- The water level and duration of flooding are both expected to increase in the Delta, particularly in the wet season.
- Increased rainfall and runoff, and hence, water level can be expected in the Delta, particularly in the wet season.
- Dams on the Mekong River and its tributaries have little effect on water flows in the wet season, but the sequencing of their release of water may be important, as inappropriate release of dammed water may exacerbate flood extremes (e.g., as in the Chao Prayha Basin and Bangkok during October-November 2011).
- Dams on the Mekong River and its tributaries are expected to reduce river flows in the dry season and reduce water levels in the Delta. In turn this will increasingly affect the flushing of acid soft soils (ASS). The reduced water flow in the dry season is also expected to enable increased saline intrusion in the dry season.

Mekong Delta water level, the determining factor with respect to the elevations of road embankments and bridges, is influenced by three main factors:

- Tidal movements;
- Mekong River flows in the Delta;
- Expected sea-level rise (SLR) as a result of CC.

Each of these factors should be accurately quantified with respect to design elevation, embankment cross-section, embankment slope protection, and drainage design.

The amount of water affects runoff and the drainage structures required to handle it as well as the potential damage to embankments and the drainage the structures themselves. Of direct concern would be, for example, the design and sizes of culverts and drains, and the protection of embankment slopes. The length of time that the land around the road may be flooded, together with the amount and depth of that water, may affect structural integrity via water penetration of embankments and foundations. The higher the flood, the stronger the winds (storm intensity is expected to increase with CC) and the length of time that flood-waters remain, the greater the damage to structures via water penetration, wave action and potential liquefaction of embankment material. Embankments may require more protection than designed to date (to date, that is by a layer of impervious clay cladding).

With the expected SLR, the worst possible flood scenario would occur during a Spring tide at the same time as an extreme storm event in the wet monsoon during the August to October period.

The World Bank, ADB and JICA funded investigations of probable scenarios of CC induced flooding on three SE Asian coastal cities, including HCMC. It must be noted that HCMC is not the same as the Central Mekong Delta (CMD) and that the study was confined to the effects of SLR, increased rainfall, and rainfall variability. It did not consider the effect of sea-water surges or

flash-floods. Nevertheless, the SLR estimates and rainfall quantity and seasonal variability are applicable to the CMDRCP.

The findings all bear on the designs of roads and bridges as well as the agricultural areas, settlements and land uses in the CMD that the transport infrastructure is designed to serve. Pertinent findings include:

- Future “greater seasonal variability in rainfall and increasing frequency of extreme rainfall-related storms;”
- Large increase in areas flooded and a “significant increase in both the depth and duration for both regular and extreme floods over current levels;”
- For HCMC, by 2050 expected SLR of 0.24-0.26m with storm surges of up to 1.08m.
- Land < 1.0m in elevation may be permanently flooded;
- The only land not prone to regular flooding will be > 3.0m in elevation.

The conclusions of the World Bank et al Report with respect to Bangkok are extremely modest. Recent events show how seriously CC should be taken. The Report states that the cost of flooding in Bangkok may reach US \$5B by 2050 and US \$8B by 2110. It is notable that the flood damage from the flood of 2011 is (to date) estimated to exceed US \$8B and many experts expect the final damage cost to be significantly higher than this.

### 3.11.3 Findings from Project Documents that bear on Water Levels in the CMD

Recent historical average annual rainfall in the CMD ranges from 1300mm near the coast to 1600mm near Can Tho. Most rain falls during 7-months in the April to November period. River flow and surface water flow peak during September to November (this period accounting for 50% of the annual Mekong River flow).

The Hydrological Survey indicates that the highest recorded river floods in the CMD were in 1978 (2.61m) and 2000 (flood-water level reached 0.5m above grade).

There are 2 diurnal tides, one higher than the other. The amplitude of the greater tide is 3m to 4m at the coastal estuary; the amplitude of the lesser tide is 1.5m to 2.0m. Tidal influence extends upstream beyond Long Xuyen City as far as Chau Doc near the border with Cambodia. Thus, the CMDRCP lies in the tidal zone and, as such, may be subject to CC induced sea-storm surges expected to occur in increasing frequency and intensity.

- The Due Diligence Assessment (SMEC, Jan 2011, para 51) notes that river bank scouring was assessed during the low flood period. Considering the seasonal change in river water volumes it would be prudent to assess river bank scouring under flood flows and potential CC induced flood flows.

Final embankment elevations are to be designed to the water levels determined during the Feasibility Study (FS), adjusted for CC effects. Designs in the FS are to levels 30cm above the expected worst flood level to 2050 but this level has not been thoroughly defined. To date the embankment has been designed to the 3m level. There is no clear statement focused on the issue of design elevation under CC conditions.

The SMEC, EIA Report (Jan 2011) refers to CSIRO Australia (Eastham et al, 2008) assessment of rainfall, runoff and other CC related issues in SE Asia. While the Report stresses the uncertainty of estimates, pertinent findings for the CMDRCP include:

- Annual rainfall expected to increase by up to 0.36m by 2050 particularly in the wet season;
- Annual runoff is expected to increase by 21% by 2050, particularly in the wet season;
- Runoff in the Mekong Delta is estimated to increase by 0.05 to 0.1m by 2050 when 60% of agricultural land is likely to be flooded.

### 3.11.4 Deciding upon the Minimum Design Elevation to meet 1% Flood Level Criterion

	Explanation	Design Elevation - m
	<p>The 3 key factors affecting design elevation:</p> <ol style="list-style-type: none"> <li>1) 1% flood level set at 2.86m,</li> <li>2) 0.5m clearance above flood level for wave action and pavement drainage</li> <li>3) Climate Change – Sea Level Rise only (CC SLR) factor.</li> </ol> <p>CC SLR factor has not been unequivocally decided upon.</p> <p>Ministry of Natural Resources and Environment (MONRE) states SLR 0.3m by 2050, 0.4m by 2060 (50-years from date), and 0.75m by 2110 (100 year design life for bridges - in TOR).</p> <p><b>Notes:</b></p> <ol style="list-style-type: none"> <li><b>1. SLR of 0.30m by 2050 is mid-range of IPCC 4<sup>th</sup> Assessment estimates (2007).</b></li> <li><b>2. This does not include other elements of CC such as increased run-off.</b></li> </ol>	
1	The minimum design elevation used in Feasibility Study Design	3.0
2	The 1% flood level (required by the TOR) 2.86m, plus 0.5m clearance but no allowance for CC SLR. <u>This is in FS reports.</u> Also confirmed by SMEC in Due Diligence Report.	2.86 + 0.5 = <u>3.36</u>
3	Maximum flood level to date (2.61m) plus CC induced SLR of 0.25m (SMEC, Due Diligence Report), plus 0.5m clearance above flood level. <u>This is in FS reports.</u>	2.61 + 0.25 + 0.5 = <u>3.36</u>
4	Peter M suggestion: 1% flood level (2.86m) + 0.5m (above flood clearance) + CC SLR factor (MONRE 0.30m to 2050) <b>Note:</b> 100-year design life (2110) CC SLR factor (MONRE 0.75m to 2110) would give design elevation of <u>4.11m</u>	<b>2050:</b> 2.86 + 0.30 + 0.50 = <u>3.66</u> <b>2110:</b> 2.86 + 0.5 + 0.75 = = <u>4.11</u>

**The finalization of design elevation is a vital issue to be settled urgently.**

Given the probable increases in rainfall, runoff, SLR and the experience in 2011 of the floods in the Chao Prayha Basin, particularly the estuarine area in which Bangkok is situated (a similar setting to the CMD) it would be prudent to ensure adequate temporary and permanent works and site drainage.

Normal environmental management issues relate directly to the volumes of materials required. Both affect such related issues as materials transport, placement of materials, materials storage sites, works activities at construction sites, and traffic management. In the case of the CMDRCP the CC adaptations will add to potential environmental impacts through factors that bear directly on the design of embankments. For example:

- Flood amplitude:
- Rainfall intensity:
- Wind velocity:
- Temporary and permanent works and site rainage:

### 3.11.5 Conclusions

- A. River water volumes and surface water runoff can be expected to be significantly greater in the future than they have been in the past. The sea level can be expected to higher. There may be discussion on the magnitude of such increases but the probability of their occurrence continues to increase as research results and policy directions are continually improved. There are clear implications for the CMDRCP that have to be addressed urgently.
- B. There is to date no clear assessment of the implications of CC on project design elevations and the project design for structures.
- C. It is imperative that design elevations be determined adequately and accurately on the basis of thorough investigation.
- D. Culvert design apertures follow the existing Vietnam standard but it may be prudent to increase them sufficiently to handle the expected runoff (expected to increase by 21% by 2050).

### 3.11.6 Climate Change Project Work Requirements During Design Period

- Review NORAID funded CC report (expected Jan, 2012)
- Finalize CC findings and recommendations to date
- With Project Team Leader (Brian) meet Key members of Design Team to ensure mutual understanding of CC implications, and to make a decision with respect to design elevations.



# CONSTRUCTION PLANNING & PROCUREMENT

### 3.12 Project Components

The Central Mekong Delta Connectivity Project (CMDPC) consists of three components:

**Component 1** - The Cao Lanh bridge, a cable stayed structure about 2 km long and 6 lanes wide over a branch of the Mekong River, with a central span of 350m and a maximum height above high water level of 37.5m;

**Component 2** - A connecting road between the two bridges about 16 km long, designed to 6 lane expressway standard and constructed initially to 4 lanes;

**Component 3** - The Vam Cong Bridge, similar to the Cao Lanh bridge, with a central span of 450m (consisting of Component 3A, the bridge itself, and Component 3B, the bridge approaches).

### 3.13 General Approach to Procurement

The Consultant will ensure that the Procurement prepared for the CMDPC Project complies fully with the requirements of the Executing Agency (EA) and ADB's latest version of the Guidelines for Procurement latest version.

The consultant will assist CUU LONG CIPM and MOT with procurement of the project's civil works (not including for Component 3A, which will be managed separately by CUU LONG CIPM and the consultant for the GOK-financed works). This assistance will be provided under the detailed design and procurement support part of the services. Bidding documents will comprise prequalification invitation documents, prequalification evaluation documents and bidding documents for the civil works, including the tolling and traffic control systems. Bidding documents will also include all environmental mitigation measures specified in the EMP, and HIV/AIDS awareness and prevention programs.

The Consultant will prepare a procurement plan for the works including proposed contract packages, proposed procurement method, a proposed schedule for procurement.

### 3.14 Construction Planning and Packaging of works

The Consultant will develop a contract packaging plan with tentative dates for inclusion in tender documents and highlighting the interface requirements between contracts. Tentative packages for the Civil Works will be formulated, discussed and agreed with the CUU LONG CIPM

The Consultant will assist CUU LONG CIPM with developing a procurement approach for each of the contract packages, which may include for Component 1 (i) the two stage two envelope bidding process detailed in ADB's procurement Guidelines; and (ii) a lump sum contract in preference to a schedule of rates contract. The two-stage approach will allow EA to assess technical aspects of bidders' proposals prior to receiving final financial bids.



### 3.15 Preparation of Bidding Documents

The Consultant will prepare all documents necessary for procurement of the works: prequalification invitation documents, prequalification evaluation documents and bidding documents for the civil works.

Bill of Quantities will be prepared and cost estimates will be produced using unit rates to suit both the site conditions and material supply and demand. The Bill of Quantities will include items also for environmental mitigation measures and HIV/AIDS awareness and prevention program for contractors' workers. The bidding documents will include provisions regarding gender issues and possible employment opportunities for ethnic minority groups. In a similar manner the bidding documents for the toll and traffic control systems (TCS) will be prepared.

### 3.16 Pre-construction Activities - Prequalification and tendering

The Consultant will provide assistance in the general administration of the tender process working closely with CUU LONG CIPM /MOT in order to ensure that bidding documents are fully prepared prior to commencing the bidding. We will assist in preparing the prequalification documents and in addition assistance will be provided in reviewing the applications for prequalification received from potential bidders and preparing an evaluation report.

The Consultant will participate in the selection procedures of the works contracts consisting the phases: preparation of tendering, prequalification phase, tendering period, tender evaluation and contract preparation.

Assistance during the tendering will include: organizing and conducting the site visits and clarification meetings, assisting the client in answering tenderer's enquiries, advising on contractual and procedural matters in compliance with ADB's Procurement Guidelines. In response to questions raised by the bidders our procurement expert will refer technical matters to the team's engineering specialists.

Assistance during the tender evaluation will include: providing guidance and advice to the evaluation committee, monitoring the evaluation process to ensure compliance with the specific provisions of the tender documents, assisting the client in preparing the tender evaluation report. During the submission of tender evaluation report the Consultant will submit for endorsement a contract dossier for the proposed contract. The Consultant will also assist the client with contract negotiation and finalizing the contract.

## SECTION 4

# STAFF ORGANIZATION, WORK PLAN & PERSONNEL

## 4. Staff Organization, Work Plan and Personnel

### 4.1 General

The sections below give details of the Consultant’s organization and sequence of work to ensure that the overall objectives of the Project are delivered. A Project Office has been set up in Ho Chi Minh City to accommodate the Project Team, as required, and provide the necessary project administration support. The Project Manager is based in this office, which is conveniently located nearby to the Client’s office.

### 4.2 Project Organization

The Project Organization Chart of the current staffing structure for the Detailed Design and Procurement stage has been developed. The Consultant’s team, led by its Project Manager, will function as technical experts in providing the consulting services specified in the Terms of Reference. A copy of the Organization Chart is included at Annex A of this report.

### 4.3 Work Schedule

A Work Schedule for the Detailed Design and Procurement tasks has been prepared using MS Project to determine the logical sequence needed to complete the work on time. Where there are dependencies these have been included. A printout of the Project Schedule is included in Annex B of this report.

It should be noted that this schedule is based on the anticipated tasks known at this stage. The schedule will be updated when any significant changes to the scope or sequence of tasks are identified. The schedule will also be used to monitor progress of the design task.

### 4.4 Staffing Schedule

A Personnel Schedule has been prepared of current staff and those who are due to have an input during the Detailed Design and Procurement stage. The schedule was formally submitted to the Client and a copy is included at Annex C to this report.

## SECTION 5

# IDENTIFIED CONSTRAINTS

## 5. Identified Constraints

During the initial review of the Feasibility Report Design and preparation of this Inception Report the Project Team has tried to identify any issues that could have a potential impact of the design process and project implementation. A number of potential minor issues have been identified and these will be discussed with the CUU LONG CIPM during the design process. Two, what we consider being, important issues have also been identified and are listed below:

1. **Vam Cong Bridge** – The detailed design of Vam Cong Bridge is to be carried out by another consultant. It is essential that we are able to liaise with them as soon as possible to finalise the road geometry. Any change to the bridge location or elevation, however minor, will have an impact on the adjacent roadway and bridge structures forming part of our project. We understand that no consultant has been appointed yet to the Vam Cong project and this could have implication on our design and schedule.
2. **Project Procurement (Construction) Packages** – It is imperative that an early decision is made on the procurement packages for the project – particularly for the civil work as this will have a direct impact on drawing production (drawing numbers and other details such as the indication of limit of the works, etc.). As the drawing numbers and organisation of work is to be set up early in the design period the packaging information is urgently required. Furthermore, the calculation of quantities and cost estimates will also be dependent on the actual packages to be adopted.
3. **Climate Change** – As discussed in Section 3.11 of this Inception Report, the rationale for determining the minimum design level needs to be agreed. The current 3.0m design level used in the FS Design would be lower than the predicted high water level which includes allowance for Climate Change to sea water levels. It should be noted that further allowance may be required for other elements of Climate Change such as increased run-off.
4. **Additional Geotechnical Work** – Agreement and decision on the extent of additional boreholes at interchanges and other locations needs to be taken as soon as possible to maintain the current design schedule.

# Annex A

## Staff Organization Chart

# Annex B

## Project Schedule



# Annex C

## Staff Schedule

### MOBILIZATION SCHEDULE FOR INTERNATIONAL STAFF

NO.	NAME	POSITION	MOBILIZATION DATE	COMMENTS
INT001A	Brian Barwick	Team Leader	24 November 2011	MOBILIZED
INT002A	Joselito Supangco	Financial Analyst	24 September 2012	
INT003A	Colin Mellor	Monitoring & Evaluation Sp'list	27 August 2012	
INT004A	TBC	Institutional Specialist – CUU LONG CIPM Capacity Development	23 July 2012	
INT005A	Derek Sherman	Transport Economist	24 September 2012	
INT006A	Esko Jarvenpaa	Senior Bridge Design Engineer	09 November 2011	MOBILIZED
INT007A.1	Ki Eop Eom	Bridge Design Engineer 1	09 December 2011	Alternate candidate proposed
INT007A.2	Sun Woo Lee	Bridge Design Engineer 2	09 December 2001	Alternate candidate proposed
INT007A.3	Antti Karjalainen	Bridge Design Engineer 3	21 May 2012	Mobilized in home office
INT008A	Jang Hee Lee	Senior Geotechnical Engineer	15 November 2011	MOBILIZED
INT009A	Young Il Jang	Geotechnical Engineer	15 November 2011	MOBILIZED
INT010A	Tony Green	Senior Hydraulic Engineer	12 December 2011	
INT011A.1	Markus Saari	Hydraulic Engineer 1	12 December 2011	
INT011A.2	Joao Santa Clara	Hydraulic Engineer 2	12 December 2011	
INT012A	Nihal Alagoda	Senior Road Design Engineer	07 December 2011	
INT013A	Zafar Chowdhury	Senior Pavement Design Eng.	23 April 2012	
INT014A	Min Der Day	Transport, Toll and Traffic Systems Engineer	23 July 2012	
INT015A	Naty Ruby Umlas	Road Design Engineer	23 January 2012	
INT016A	Dr. Kwok Yan Wong	Geotechnical Engineer (Roads)	14 November 2011	MOBILIZED
INT017A	Atte Mikkonen	Structural Engineer	24 November 2011	MOBILIZED
INT018A	Mauri Mottonen	Senior Procurement Specialist	23 April 2012	
INT019A	John Ward	Cost Estimating Engineer	23 July 2012	
INT020A	Jean Williams	Resettlement/Social Development Specialist	09 December 2011	Already mobilized in home office
INT021A	Peter Marriott	Environmental Specialist	01 December 2011	MOBILIZED
INT022A	Various	Home Office Senior Engineers	09 December 2011	
INT023A	Various	Home Office Engineers	09 December 2011	

### INTERNATIONAL STAFF TO BE MOBILIZED BUT NOT LISTED IN PROPOSAL

NO.	NAME	POSITION	MOBILIZATION DATE	COMMENTS
	Firas Al Zubaidi	Road Design Engineer	07 December 2011	
	George Heritage	Hydraulic Engineer 3	12 December 2011	
	Kang Hyun Tae	Principal Structural Engineer	24 November 2011	

### MOBILIZATION SCHEDULE FOR LOCAL STAFF

NO.	NAME	POSITION	MOBILIZATION DATE	COMMENTS
NAT001A	Ngo Tran Trong Le	Deputy Project Manager	23 December 2011	Late mobilization due to <b>unavailability</b> of original person
NAT002A	Ngo Thuy Quynh	Monitoring and Evaluation Specialist	26 March 2012	
NAT003A.1	Hoang Than Hai	Senior Bridge Design Engineer 1	24 November 2011	MOBILIZED
NAT003A.2	TBC	Senior Bridge Design Engineer 2	07 March 2012	
NAT004A.1	Oach Huu Nghia	Bridge Design Engineer 1	24 November 2011	MOBILIZED
NAT004A.2	Ngo Van Cung	Bridge Design Engineer 2	24 November 2011	MOBILIZED (listed as TBC in contract)
NAT004A.3	Vu Van Hai	Bridge Design Engineer 3	24 November 2011	MOBILIZED (listed as TBC in contract)
NAT005A	Pham Xuan Binh	Senior Geotechnical Engineer	28 November 2011	MOBILIZED
NAT006A.1	Nguyen Cao Son	Geotechnical Engineer 1	01 December 2011	MOBILIZED
NAT006A.2	TBC	Geotechnical Engineer 2	05 March 2012	
NAT007A	Ngo Duy Dong	Senior Hydraulic Engineer	05 December 2011	MOBILIZED
NAT008A.1		Hydraulic Engineer 1		Position deleted – moved to international input
NAT008A.2		Hydraulic Engineer 2		Position deleted – moved to international input
NAT009A	Do Minh Dzung	Senior Road Design Engineer	DATE	
NAT010A	Nguyen Duc Nam	Senior Architect (Toll Bldgs., Plazas etc.)	25 June 2012	
NAT011A	TBC	Transport, Toll and Traffic System Engineer	05 March 2012	
NAT012A.1	Dinh Hong Hai	Road Design Engineer 1	05 December 2011	MOBILIZED
NAT012A.2	Nguyen Trung Thanh	Road Design Engineer 2	05 December 2011	MOBILIZED
NAT013A	TBC	Geotechnical Engineer	05 December 2011	
NAT014A.1	Ho Huy Hung	Structural Engineer 1	24 November 2011	MOBILIZED (listed as TBC in contract)
NAT014A.2	Le Khanh Hung	Structural Engineer 2	24 November 2011	MOBILIZED (listed as TBC in contract)
NAT014A.3	Vu Tien Long	Structural Engineer 3	24 November 2011	MOBILIZED (listed as TBC in contract)
NAT015A	Nguyen Xuan Thuy	Procurement Specialist	05 March 2012	
NAT016A	TBC	Cost Estimating Engineer	07 March 2012	
NAT017A	Trinh Thi Thu Ha	Senior Resettlement Specialist	05 December 2011	MOBILIZED
NAT018A	TBC	Resettlement Specialist	05 December 2011	
NAT019A	Nguyen Thi Thanh Tam	Social Development/Gender Specialist	07 December 2011	
NAT020A	TBC	Social Development Specialist	26 March 2012	
NAT021A	Dao Quang Vinh	HIV/AIDS Specialist	27 February 2012	
NAT022A	Hoang Trung Thanh	Environmental Specialist	27 February 2012	